

NSK

LONG-LIFE SPLIT CYLINDRICAL ROLLER BEARING UNITS

FOR SEGMENTED DRIVE ROLLS OF CONTINUOUS CASTING MACHINES

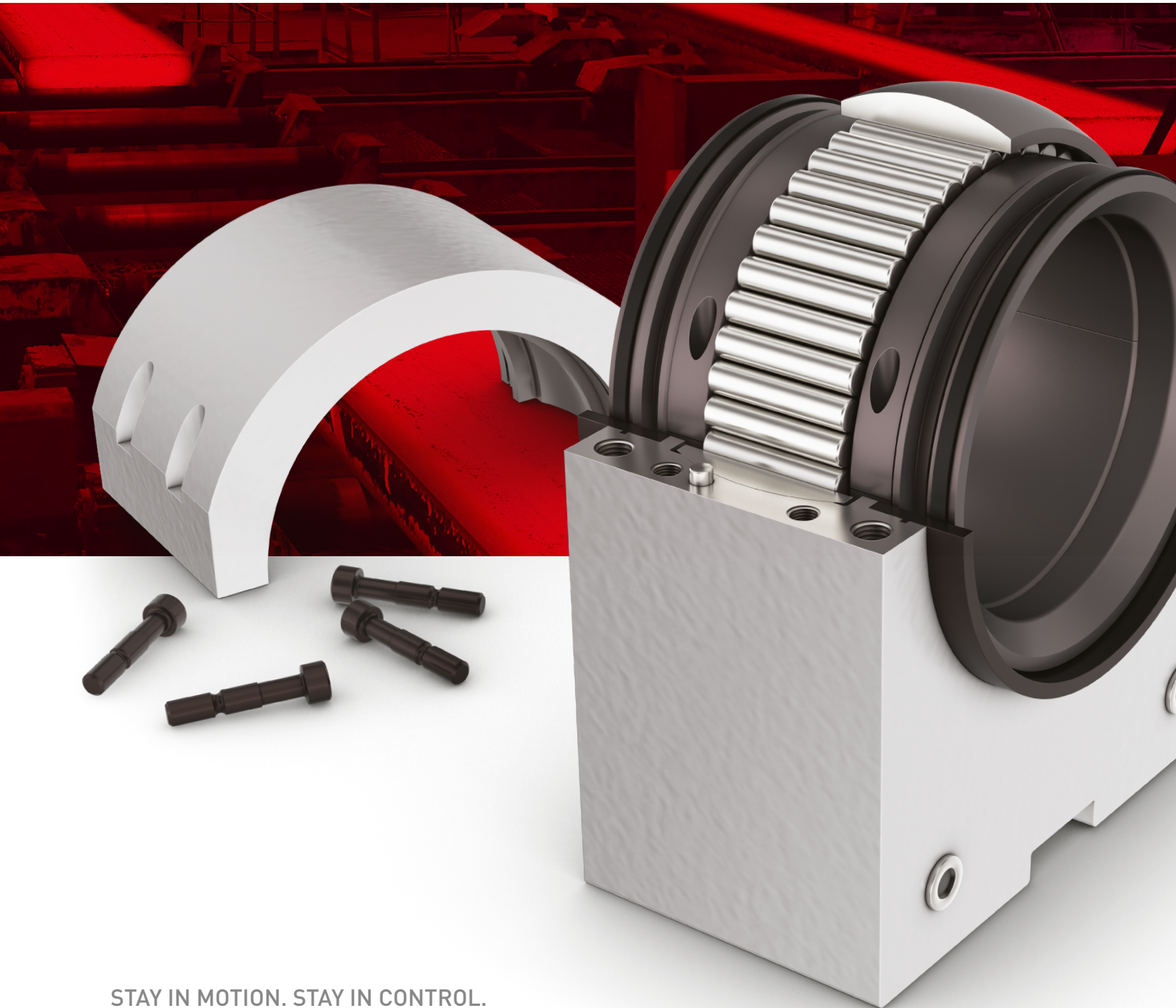

STAY IN MOTION. STAY IN CONTROL.

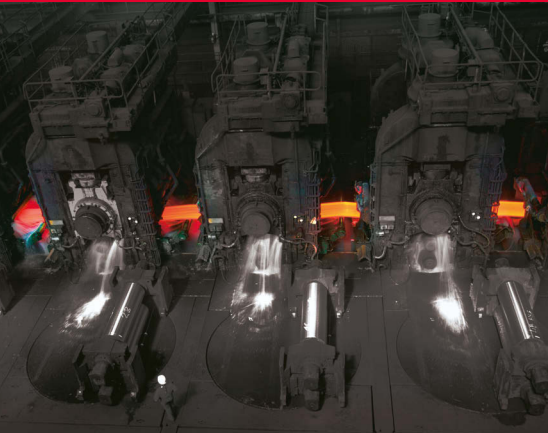

MADE WITH METTLE

BEARINGS FOR STEEL AND METALS MACHINERY

Massive loads. Intense heat. Extreme high speeds, ultra-low speeds, and everything in between. Staggering shock loads, misalignment, and contamination from mill scale and water vapor. From primary iron and steel making through rolling and forming mills, the operating conditions of the entire process are severe. The reliable, uninterrupted performance of rolling components is critical for accelerated production. For NSK, our product development and design is focused squarely on withstanding the manifold operating stresses of these applications with:

- › increasing capacities for high loads and high speeds
- › advanced materials for durability, wear resistance and longer life
- › lubrication and seal technology for smooth and clean running

Our product solutions are designed to optimize the performance of machinery and equipment, to assure predictable reliability and to deliver total cost-efficiency.

SPLIT CYLINDRICAL ROLLER BEARING UNITS

NSK Split Cylindrical Roller Bearing Units are ideally designed to simplify bearing replacement in segmented drive rolls of continuous casting lines, eliminating the complexity of dismantling the roll and thereby reducing total maintenance downtime. But not at the expense of performance. Optimized roller length and profile delivers high capacity and reduced wear. And an advanced seal arrangement prevents water and particle ingress and grease leakage. It also improves performance when employing oil-air lubrication. Inside and out, NSK Split Cylindrical Roller Bearing Units are engineered to deliver utmost capacity and efficiency for a long bearing life.



PROVEN ADVANTAGES

- › Simplified bearing installation with split design
- › Optimized cylindrical roller length and profile deliver high load capacity with reduce wear
- › Advanced seal configuration provides optimal barrier to contaminant ingress and prevents grease leakage
- › Specially designed non-contact labyrinth seal ring facilitates efficient oil-air lubrication

BEARING DIMENSIONS AND OPERATING VALUES

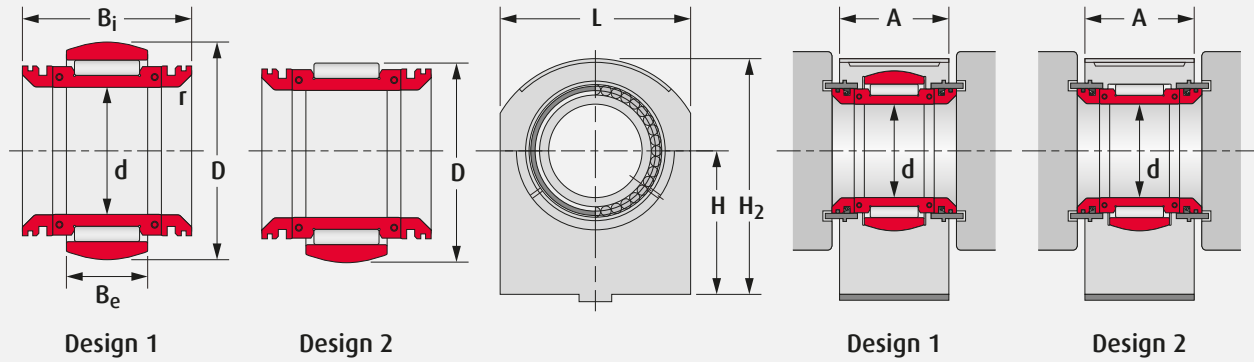

ROLL DIA. mm	BASIC BEARING NO.		BEARING DIMENSIONS					BASIC LOAD RATINGS kN		HOUSING DIMENSIONS				DESIGN
			mm							mm				
	BEARING	HOUSING	d	D	B_i	B_e	r	Dyn.	Stat.	L	A	H	H_2	
225	100RNPH1801	100PCR2201	100	185	169	74	15	475	950	235	152	132	234.5	2
230	110RNPH1801	110PCR2301	110	180	137	49	15	272	570	230	120	160	265	2
230	110RNPH1803	110PCR2303		185	154	76	20	450	1 070	230	135	180	285	2
250	110RNPH2001	110PCR2502	120	200	179	80	20	535	1 090	250	156	150	263.5	2
240	115RNPH2001	115PCR2401		115	205	202	98	15	625	1 460	245	183	190	300
250	120RNPH1901	120PCR2501	130	195	157	66	20	410	950	250	142	165	278.5	2
255	120RNPH2001	120PCR2502		205	179	80	20	560	1 220	255	162	230	347.5	2
270	130RNP2001	130PCR2701	135	205	139	60	20	455	1 030	265	118	190	313.5	1
280	130RNP2101	130PCR2801		215	174	75	20	540	1 190	280	156	160	290	1
250	130RNPH2105	130PCR2705	140	215	143	60	20	460	975	270	132	197	313	2
250	130RNPH2107	130PCR2604		215	174	75	20	550	1 230	265	175	145	260	2
280	130RNPH2201	130PCR2802	140	225	189	90	20	670	1 460	280	172	180	308.5	2
280	130RNPH2202	130PCR2603		220	186	79	20	555	1 370	265	171	175	295	2
250	135RNPH2101	135PCR2701	140	215	183	84	20	570	1 350	270	160	160	275	2
250	135RNPH2102	135PCR2502		210	183	84	20	515	1 350	250	160	160	275	2
270	140RNPH2102	140PCR2701	140	215	162	60	20	415	950	270	145	180	305	2
265	140RNPH2103	140PCR2601		215	189	74	20	490	1 170	265	174	175	300	2
285	140RNPH2302	140PCR2804	140	235	194	84	20	665	1 530	285	179	175	305	2
310	140RNP2401	140PCR3101		245	184	85	20	710	1 510	310	166	175	320	1

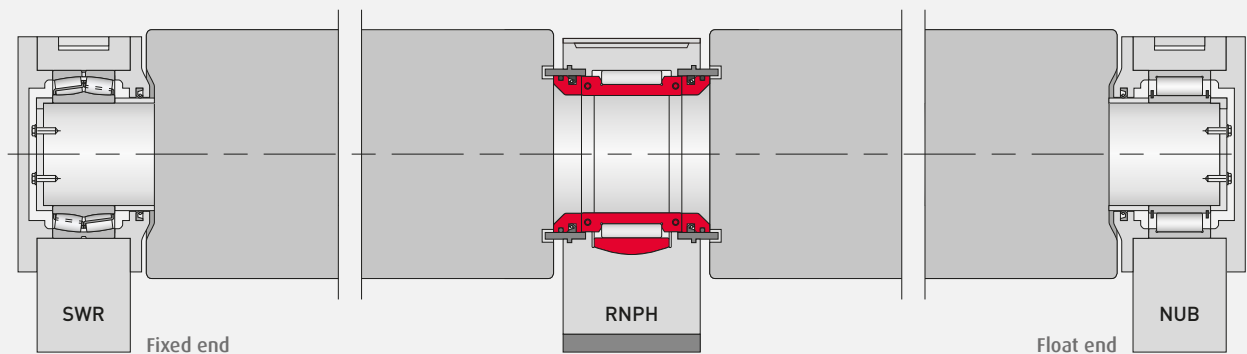

Illustrated: Segmented drive roll with Split Cylindrical Roller Bearing Units used in conjunction with NSK's SWR Spherical Roller Bearings and NUB Cylindrical Roller Bearings.

ROLL DIA. mm	BASIC BEARING NO.		BEARING DIMENSIONS						BASIC LOAD RATINGS kN		HOUSING DIMENSIONS				DESIGN
			mm								mm				
	BEARING	HOUSING	d	D	B _i	B _e	r	Dyn.	Stat.	L	A	H	H ₂		
280	145RNPH2201	145PCR2801	145	225	179	76	20	560	1 340	280	162	250	380	2	
280	145RNPH2303	145PCR2804		232	196	84	20	630	1 440	280	183	260	390	2	
295	145RNPH2401	145PCR2901		240	208	89	20	765	1 780	295	195	270	407.5	2	
280	150RNPH2303	150PCR2801	150	230	199	78	20	555	1 340	280	184	175	305	2	
280	150RNPH2401	150PCR2804		245	159	80	20	680	1 550	330	144	310	440	2	
290	150RNPH2403	150PCR3004		240	195	84	18	690	1 630	305	180	205.5	336	2	
300	150RNPH2503	150PCR3003		250	169	70	20	640	1 500	300	150	180	320	2	
295	150RNPH2505	150PCR2901		250	208	89	20	780	1 840	295	193	310	447.5	2	
320	150RNPH2601	150PCR3203		265	187	98	20	900	1 950	320	168	220	365	2	
330	150RNPH2702	150PCR3301		275	199	100	20	945	1 970	330	182	220	373.5	2	
300	155RNPH2401	155PCR3001	155	245	199	88	20	740	1 720	300	182	260	400	2	
310	160RNPH2502	160PCR3101	160	255	199	90	20	735	1 730	310	178	185	323.5	2	
305	160RNPH2504	160PCR3002		255	189	86	20	745	1 780	305	174	217	357	2	
320	160RNPH2601	160PCR3302		265	200	82	20	745	1 700	330	185	225	365	2	
325	160RNPH2703	160PCR3401		275	214	100	25	945	2 190	240	199	200	347	2	
330	170RNPH2601	170PCR3301	170	265	214	100	20	880	2 050	320	194	290.5	445.5	2	
335	180RNPH2901	180PCR3301	180	290	214	85	20	880	2 050	335	150	217.5	375	2	

Additional sizes are available. Please contact NSK.



NSK AMERICAS

United States
NSK Corporation
Ann Arbor MI
1.888.446.5675

Canada
NSK Canada Inc.
Mississauga ON
1.888.603.7667

Mexico
NSK Rodamientos Mexicana,
S.A. de C.V.
Silao Guanajuato MX
52.472.500.9500

Brazil
NSK Brasil Ltda.
Sao Paulo SP
55.11.3269.4700

Argentina
NSK Argentina SRL
Buenos Aires
54.11.4762.6556

Latin America
NSK Latin America Inc.
Miami FL
1.305.477.0605

Website:
www.nskmetals.com

NSK Americas:
www.nskamericas.com

NSK Global:
www.nsk.com

Every care has been taken to ensure the accuracy of the data contained in this brochure, but no liability can be accepted for any loss or damage suffered through errors or omissions.

Printed in the USA ©NSK 2021.
The contents of the publication are the copyright of the publishers.