

NSK Linear Guides™

High-Rigidity Series

RA/RB Model Roller Guides

Thanks to NSK's advanced analysis technologies, RA/RB roller guides realize super-high load capacity and rigidity. RA models with interchangeable rails and roller slides provide set preload and accuracy for custom combinations, while the RB model with low mounting height facilitates compact machine design.

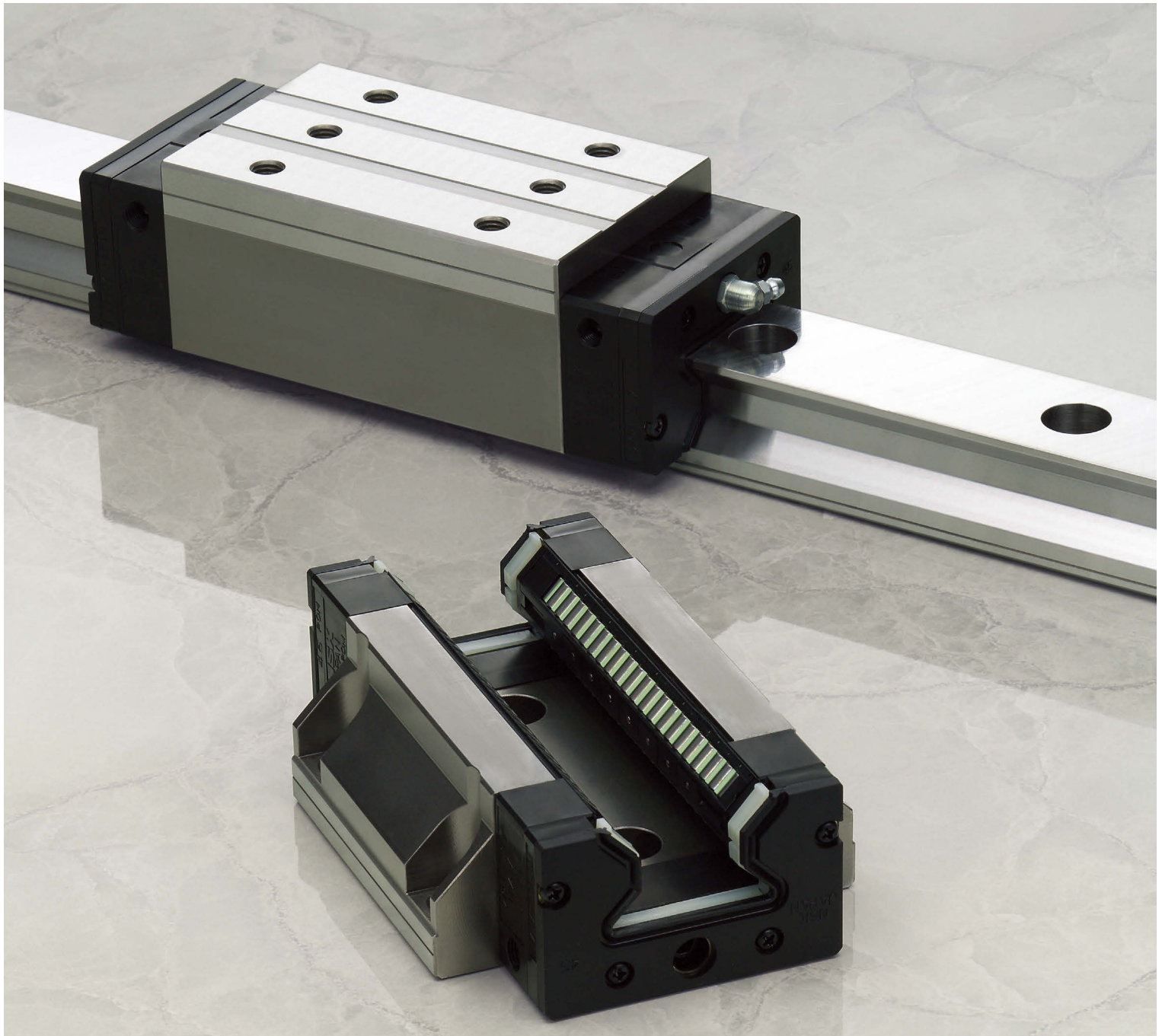

The fruits of NSK's comprehensive technologies: RA/RB roller guides suit a wide range of applications

RA/RB roller guides represent the culmination of NSK's extensive experience in roller bearings and linear guide technologies.

Their optimized designs take full advantage of our unique expertise to realize smooth motion and super-high load capacity, rigidity, and motion accuracy. With their capacity to handle a variety of applications, RA/RB models help support higher machine performance to meet your needs.

Helping to achieve higher machine performance: Features of RA/RB roller guides

Super-Long Life

Super-high load capacity

RA/RB roller guides are among the best in the world—with unprecedented operating life thanks to their high load capacity.

Maintenance-free

Installing the NSK K1™ lubrication unit assures long-term, maintenance-free operation.

Highly dust resistant

Highly dust-resistant seals come equipped as standard to prevent the entry of foreign matter and ensure that performance does not worsen over time.

Help Advance High-Precision Manufacturing

Super-high rigidity

Super-high rigidity provides high-precision manufacturing.

Super-high motion accuracy

Coupled with NSK's unique design approach, the vibration caused by roller passage has been substantially reduced. This helps improve the quality of machined surfaces.

Smooth motion

The installation of a retaining piece achieves smooth motion, resulting in stable positioning accuracy.

Ideal Across Fields

Complete lineup

A wide lineup of sizes, including low-profile varieties, are available to match your application needs.

Standardized mounting dimensions

Outside dimensions and mounting dimensions conform to commonly used standards, allowing RA roller guides to be used without design changes (see Pages 17 and 18 for details).

Super low-profile RB model

With a low mounting height, the RB model supports compact machines and equipment downsizing.

Low friction

Using rollers for rolling elements suppresses dynamic friction.



Optimal Design

NSK conducts comprehensive and detailed performance simulations of roller guides by combining analysis and tribology technologies cultivated over many years of experience. These advancements have allowed us to attain thoroughly optimized designs down to the dimensions and shapes of the guide components.

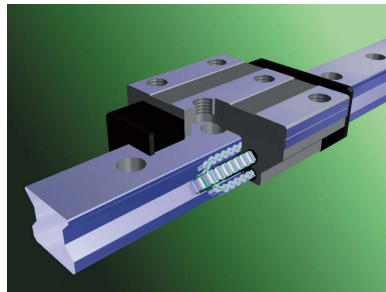

Smooth motion by use of retaining pieces

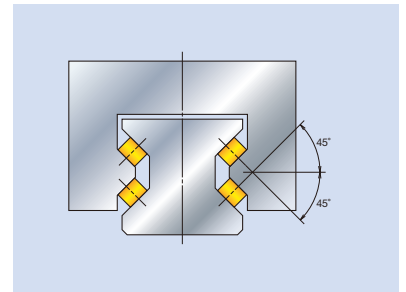

Balanced four-directional equal load specification

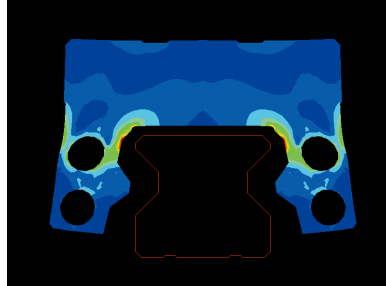

Example roller slide deformation analysis

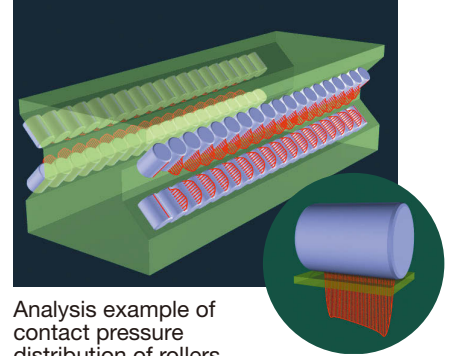

Analysis example of contact pressure distribution of rollers

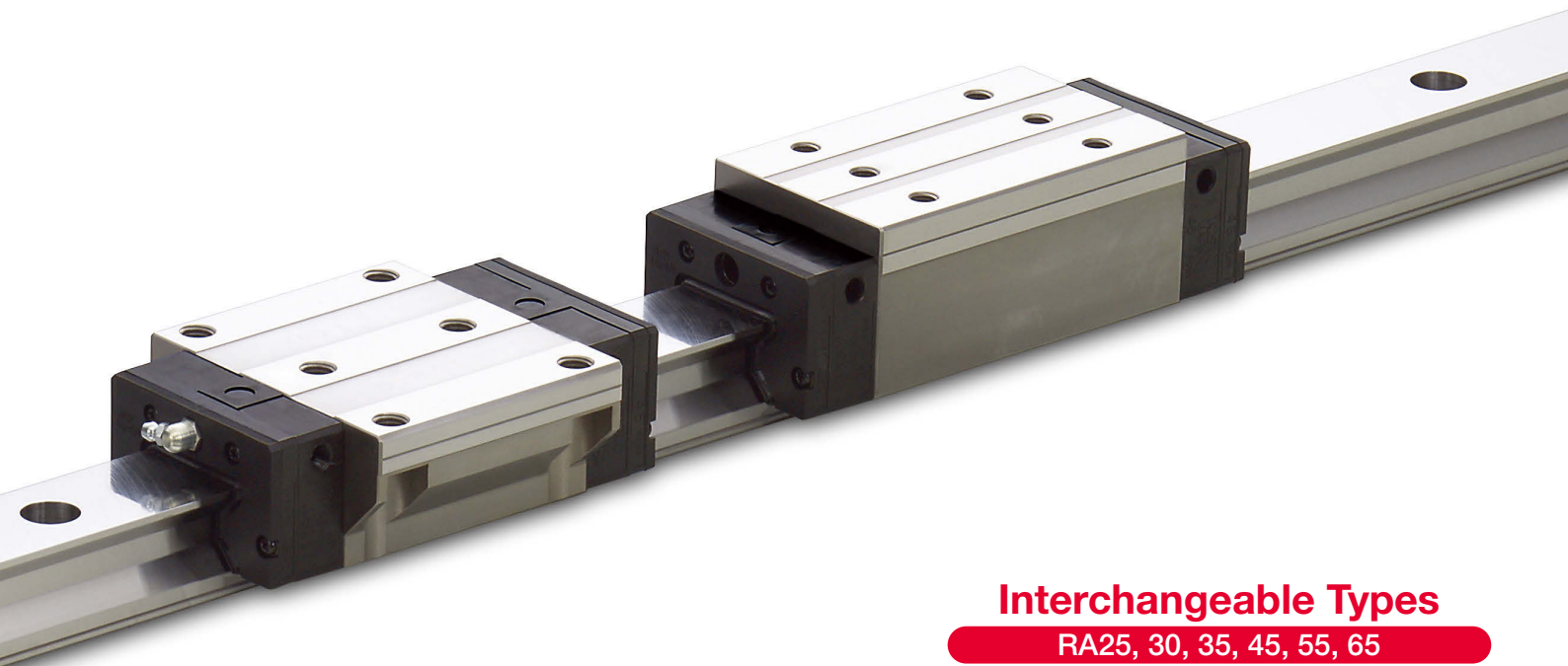

Interchangeable Types

RA25, 30, 35, 45, 55, 65

Freely Match Rails and Roller Slides

Accuracy interchangeability

High-precision (PH) grade running parallelism is maintained even with custom combinations of rails and roller slides.

Preload interchangeability

Custom combinations of interchangeable roller slides and rails provide the proper preload to maintain rigidity.

Custom matching

Rails and roller slides can be freely matched to suit the application.

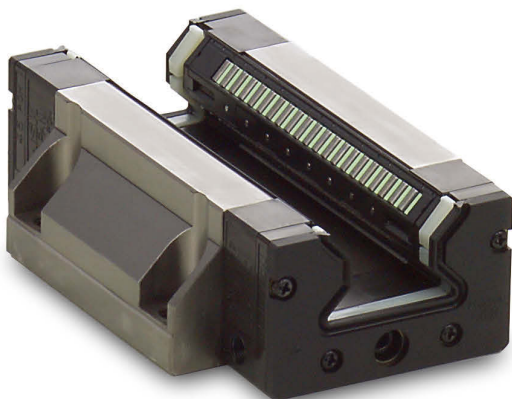

Support for multi-faceted improvements in machine performance

Features

1. Super-high load capacity

Thanks to analysis technology, we installed rollers with the largest possible diameter and length within existing standard cross-section dimensions in a logical layout to realize super-high load capacity. This design achieves super-long life and is capable of handling impact loads.

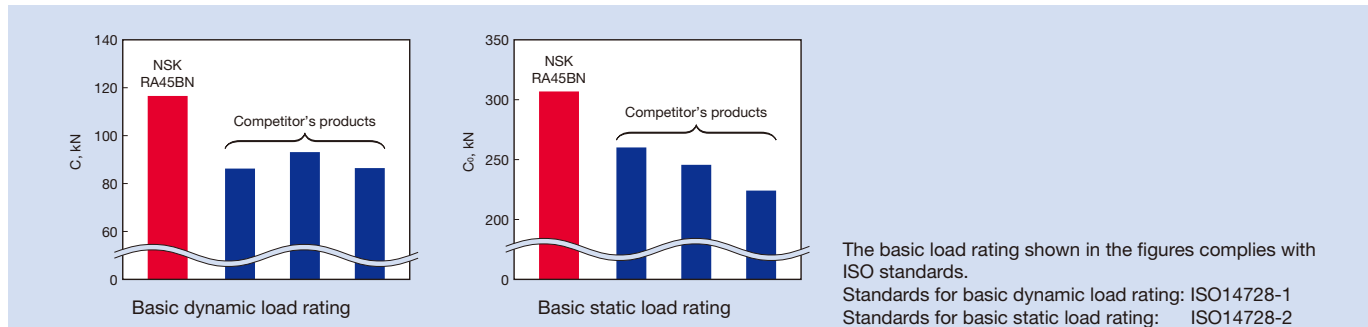

2. Super-high rigidity

Using NSK's advanced analysis technology, we pursued a complete, optimal design, down to the detailed shape of the roller slides and rails, thereby realizing super-high rigidity superior to that of competitors' roller guides.

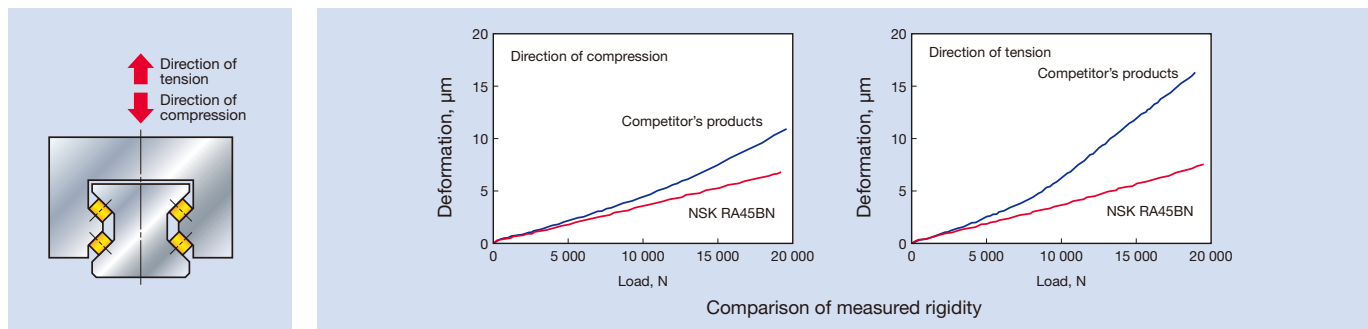

3. Super-high motion accuracy

NSK has developed its own unique method of simulating rolling element passage vibration and designing optimal roller slide specifications for damping. These developments have dramatically enhanced roller slide motion accuracy for the RA/RB models.

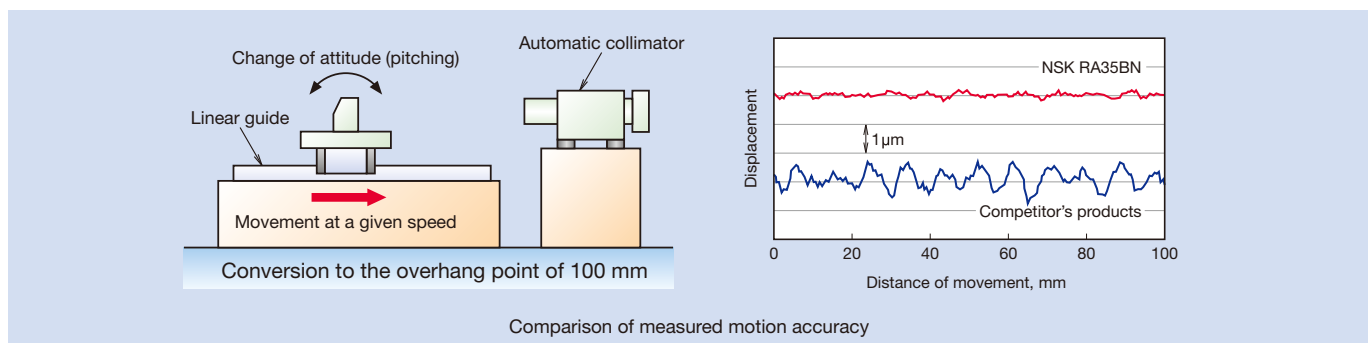

4. Standardized mounting dimensions

Outside dimensions and mounting dimensions conform to international standards, allowing RA roller guides to be used without design changes (see Pages 17 and 18 for details).

5. Smooth motion

Installing a retaining piece between rollers and restraining the skew peculiar to roller bearings achieve smooth motion. The reduction of friction variation provides stable tracking in the complicated trajectory control.

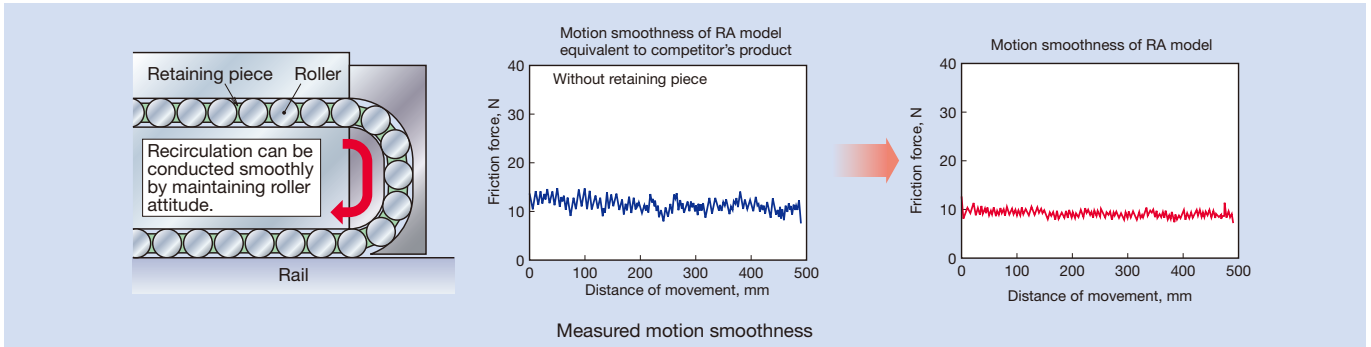

6. Low friction

Using rollers for rolling elements helps minimize dynamic friction.

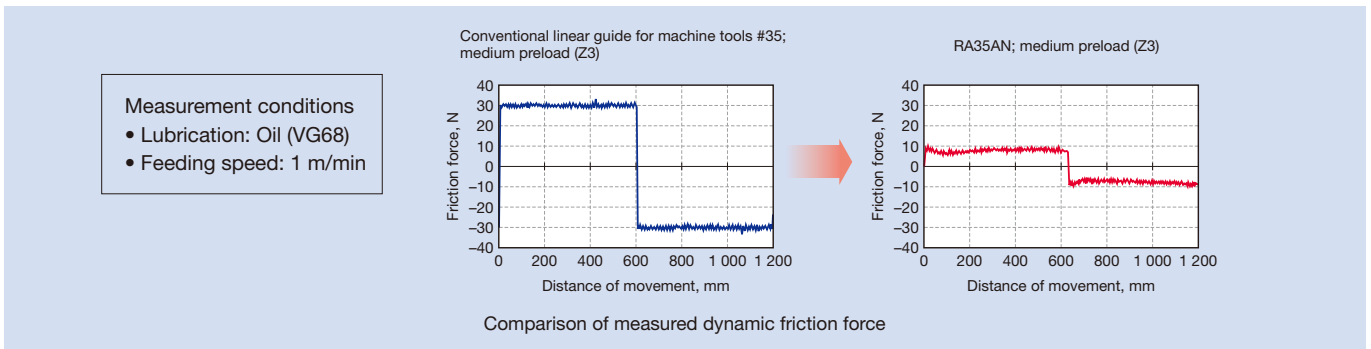

7. Low noise

A retaining piece is provided between rollers to prevent collisions and minimize noise.

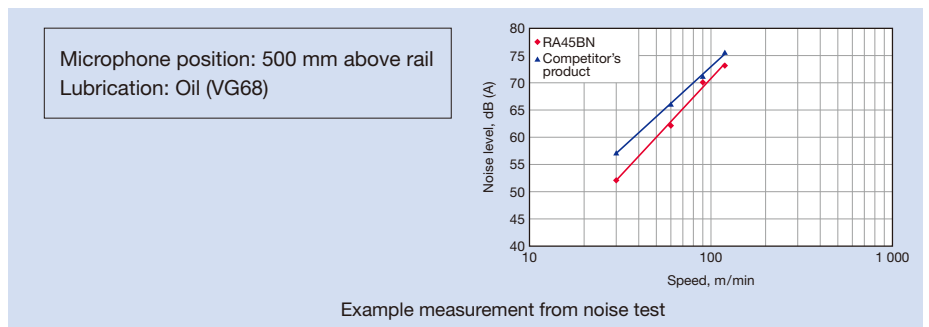

8. Highly dust-resistant, maintenance-free operation

Various roller slides, bolt-hole caps, and rail covers are available as options.

The field-proven NSK K1™ lubrication unit is also available for long-term, maintenance-free operation.

(Availability of options depends on size. For details on dust-resistant specifications, please see page 13.)

An extensive lineup that meets a wide variety of needs

Specifications

1. Roller Slide Types and Shapes

- Roller slides are available in square, flanged, and low-profile types. Compact RB models come in low-profile and flanged types, offering even lower height than RA models.
- The mounting holes of the flanged type have a tapped part used to fix the roller slide from the top surface and a tapped minor diameter section for use as bolt holes from the bottom. This allows for mounting from either the top or bottom.
- Roller slide length can be specified as the high load/standard type or the super-high load/long type.

RA model

Fig. 1 Square type

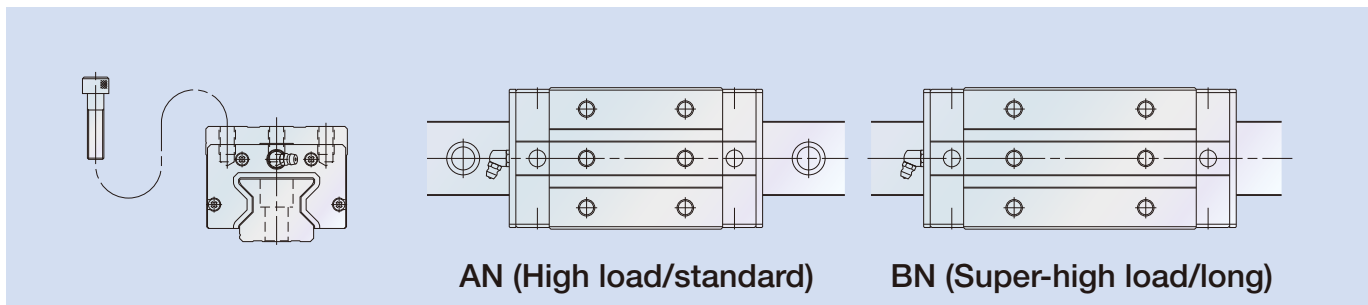

Fig. 2 Low-profile type

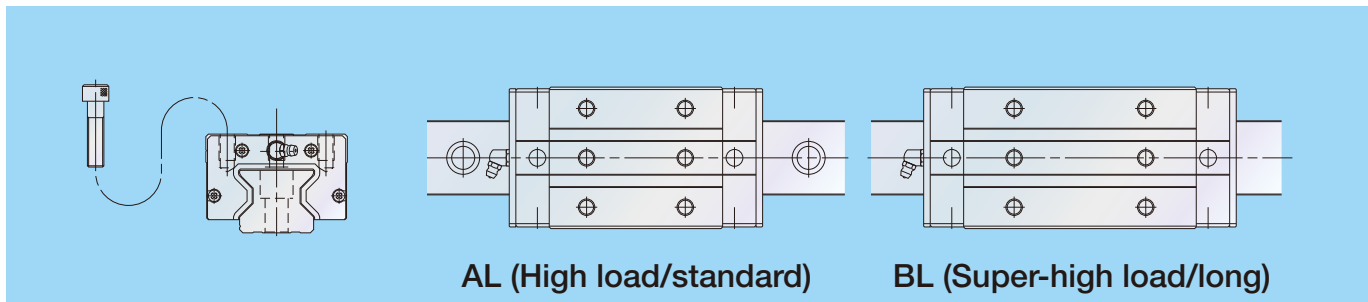
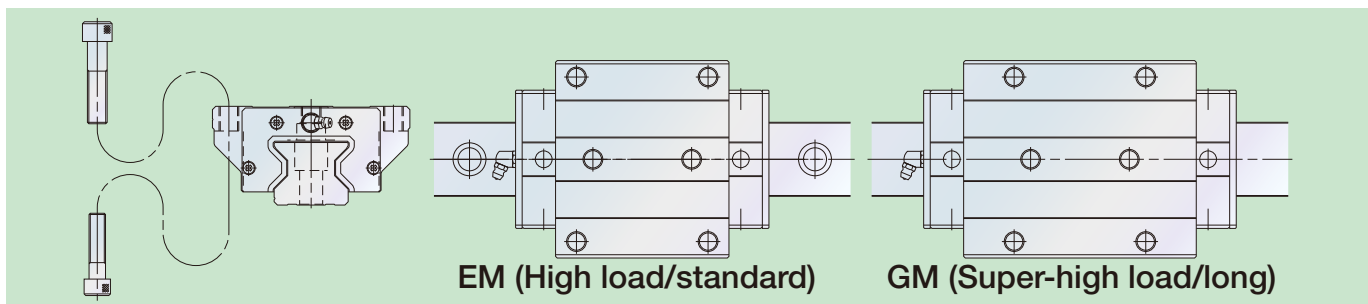

Fig. 3 Flanged type



RB model

Fig. 4 Low-profile type

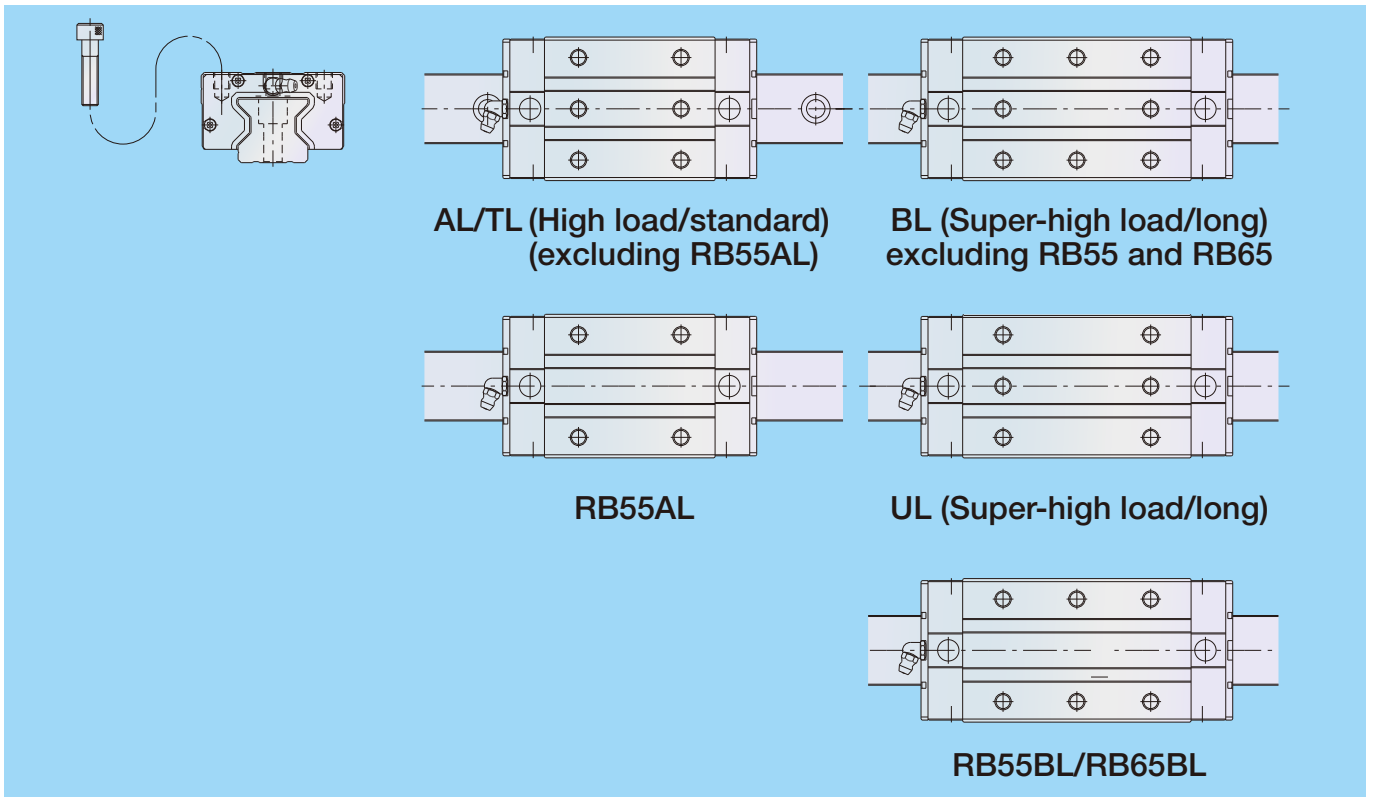
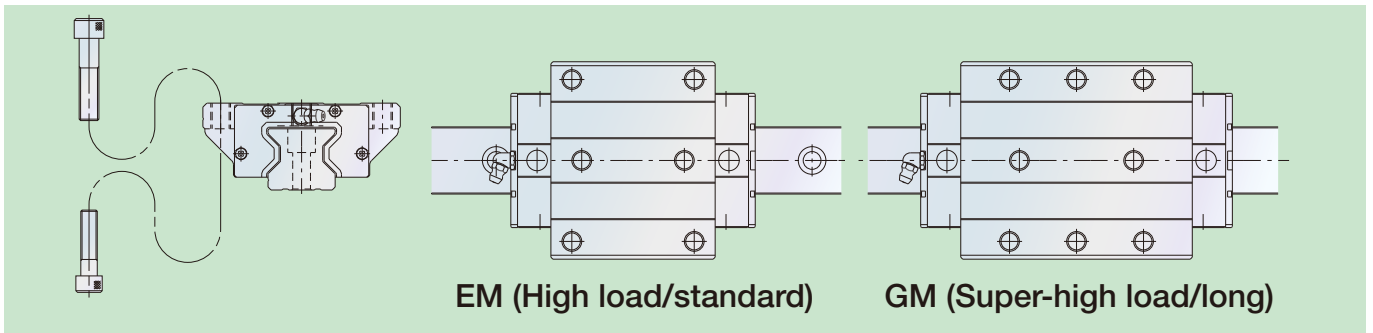

Fig. 5 Flanged type



2. Accuracy

Four accuracy grades are available for preloaded assemblies: Ultra precision P3, Super precision P4, High precision P5, and Precision P6. RA model interchangeable types offer High precision PH grade only.

Table 1 Tolerance of preloaded assembly

Characteristics	Accuracy grade			
	Ultra precision P3	Super precision P4	High precision P5	Precision grade P6
Mounting height H Variation of H (All roller slides on a set of rails)	± 8 3	± 10 5	± 20 7	± 40 15
Mounting width W_2 or W_3 Variation of W_2 or W_3 (All roller slides on reference rail)	± 10 3	± 15 7	± 25 10	± 50 20
Running parallelism of surface C to surface A Running parallelism of surface D to surface B	See Table 3 and Fig. 6			

Table 2 Tolerance of interchangeable type

Unit: μm

Characteristics	Accuracy grade	High precision PH
Mounting height H		± 20
Variation of mounting height H		15 ①
		25 ②
Mounting width W_2 or W_3		± 25
Variation of mounting width W_2 or W_3		20
Running parallelism of surface C to surface A Running parallelism of surface D to surface B		See Table 3 and Fig. 6

Note: ① Variation on the same rail ② Variation on multiple rails

Table 3 Running parallelism

Unit: μm

Rail length (mm)	Ultra precision P3	Super precision P4	High precision P5, PH	Precision grade P6
over - 50 or less	2	2	2	4
50 - 80	2	2	3	4
80 - 125	2	2	3	4
125 - 200	2	2	3.5	5
200 - 250	2	2.5	4.5	6
250 - 315	2	2.5	5	6.5
315 - 400	2	3	5.5	7
400 - 500	2	3	6	7.5
500 - 630	2	3.5	6.5	8.5
630 - 800	2	4	7	9.5
800 - 1 000	2.5	4.5	7.5	10
1 000 - 1 250	3	5	8.5	12
1 250 - 1 600	3.5	5.5	9.5	13
1 600 - 2 000	4	6.5	11	14
2 000 - 2 500	4.5	7.5	12	16
2 500 - 3 150	5.5	8.5	13	18
3 150 - 4 000	6	9.5	14	19

Fig. 6 Accuracy specifications

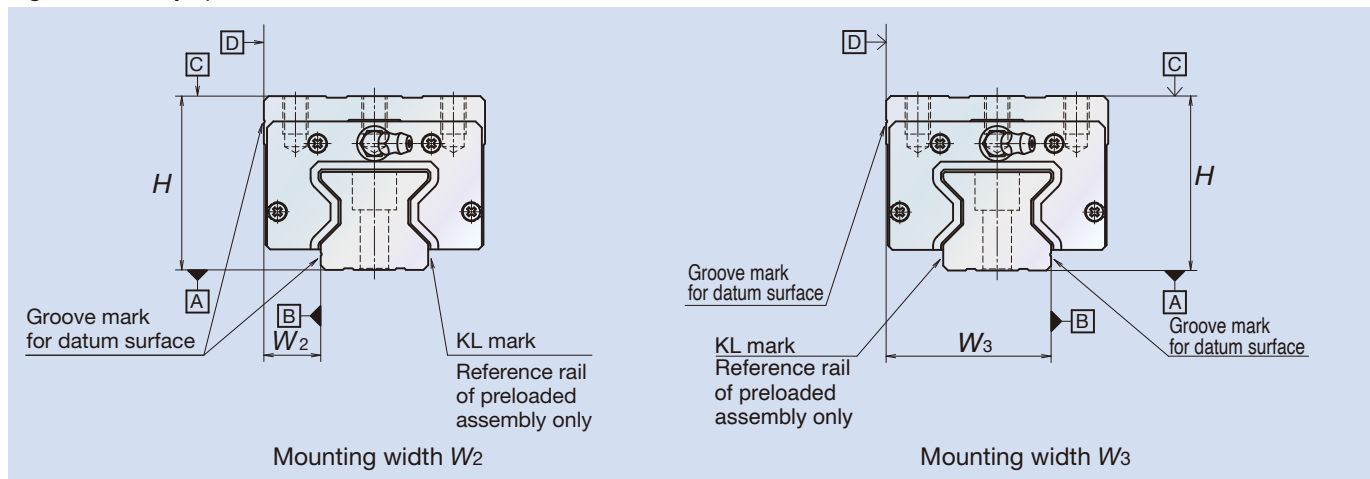

High-Rigidity Series: RA/RB Model Roller Guides

3. Preload and Rigidity

Medium preload Z3 is available for preloaded assemblies, with slight preload Z1 also available for the RA model only. Medium preload ZH and slight preload ZZ are available for the interchangeable RA model. Typical data for preload and rigidity are shown below.

Table 4 RA model: Preload

Model No.	High-load		Super-high-load	
	Slight preload (Z1)	Medium preload (Z3)	Slight preload (Z1)	Medium preload (Z3)
RA15	520	1 030	650	1 300
RA20	960	1 920	1 200	2 400
RA25	880	2 920	1 060	3 540
RA30	1 170	3 890	1 430	4 760
RA35	1 600	5 330	2 020	6 740
RA45	2 780	9 280	3 500	11 600
RA55	3 800	12 900	5 000	16 800
RA65	6 500	21 000	8 500	28 800

Unit: N

Table 5 RB model: Preload

Model No.	High-load	Super-high-load
	Medium preload (Z3)	Medium preload (Z3)
RB30	3 890	4 760
RB35	5 330	6 740
RB45	9 280	11 600
RB55	12 900	16 800
RB65	21 000	28 800

Unit: N

Fig. 7 RA model: Theoretical vertical direction rigidity

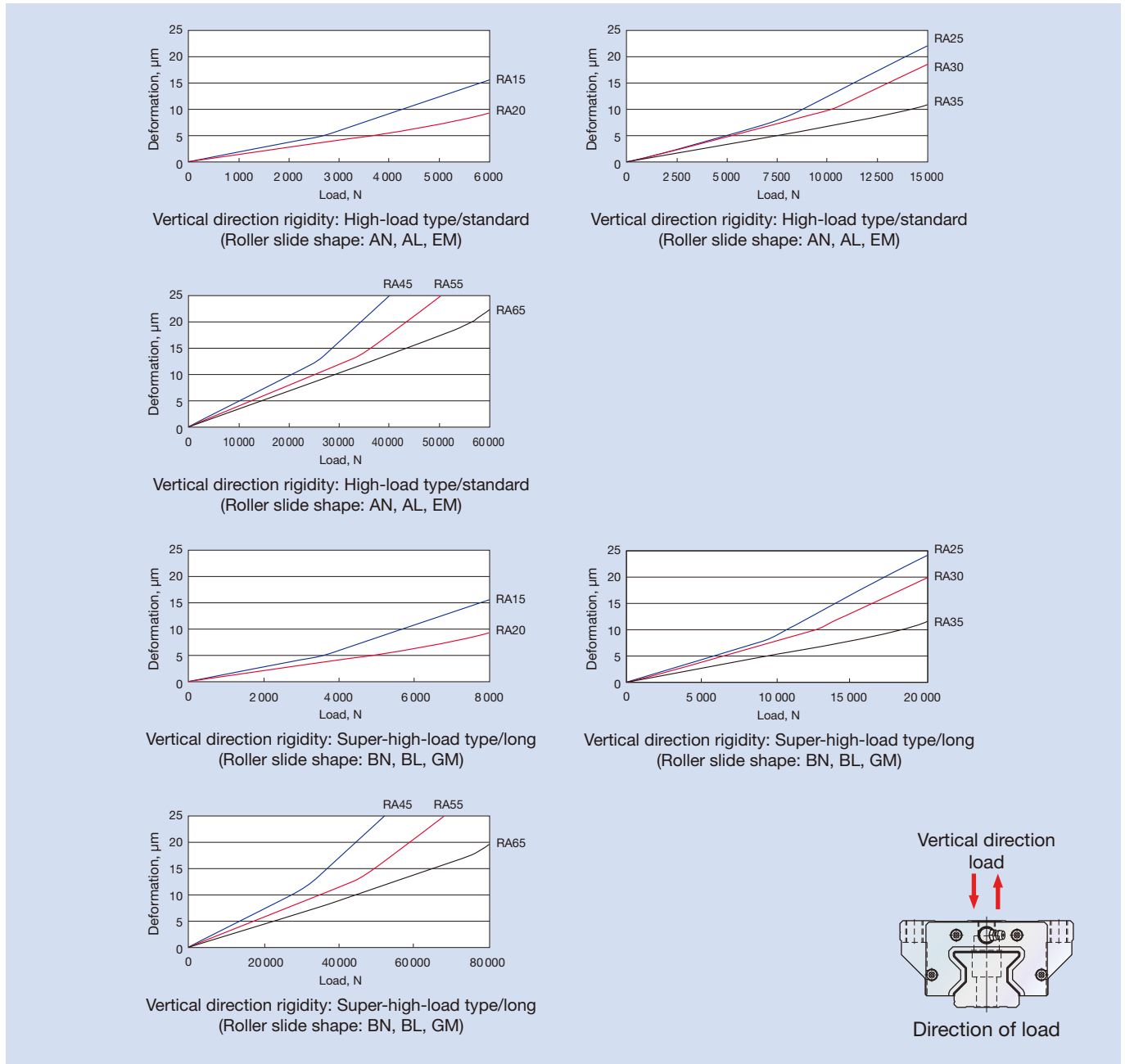
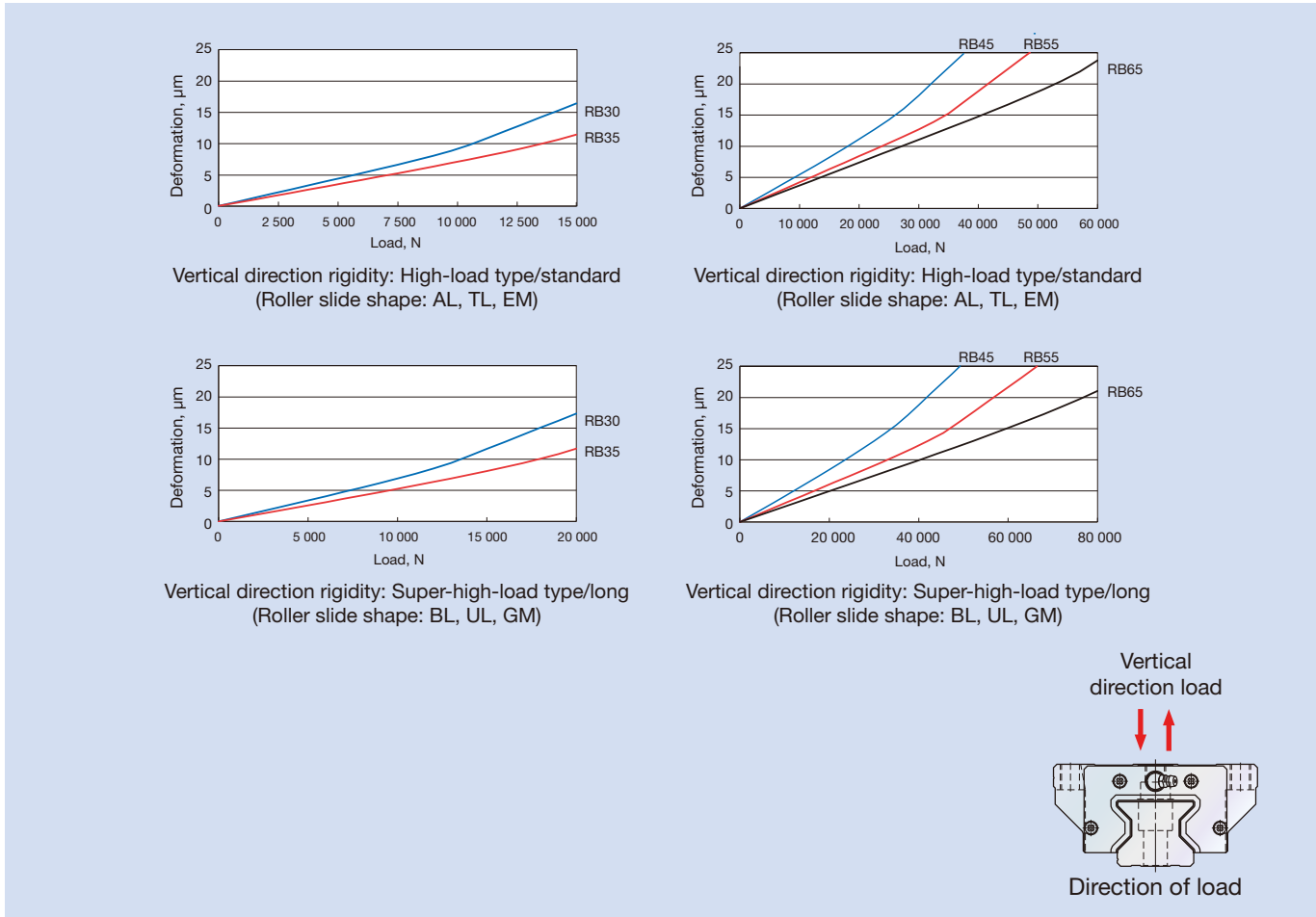

Fig. 8 RB model: Theoretical vertical direction rigidity



4. Basic Load Rating and Rated Life

The basic dynamic load rating used to specify the load capacity of a linear guide is determined by ISO standards (ISO 14728-1). The load is specified to not change in amount or direction so that the rating fatigue life is 100 km. The basic load ratings of NSK Linear Guides are based on ISO standards.

RA/RB models feature 4-way equal load specifications, making their dynamic load ratings the same in both vertical and lateral directions.

The slide's rated fatigue life L can be calculated using the following equation where load F is applied to the roller slide in only one vertical or horizontal direction.

- This life formula is different from that for linear guides with balls as the rolling elements.
- f_w refers to a load factor. Select the appropriate load factor shown in Table 6 based on vibration and impacts on the machine where the linear guide will be used.

Table 6 Load factor f_w

Impact and/or vibration	Load factor
No impacts or vibration from the outside	1.0 – 1.5
With impacts and/or vibration from the outside	1.5 – 2.0
With heavy impacts and/or vibration	2.0 – 3.0

$$L = 100 \times \left(\frac{C}{f_w \cdot F} \right)^{\frac{10}{3}} \text{ (km)}$$

Various loads may be applied to the linear guide (i.e., roller slide loads), including vertical loads, lateral loads, and moment loads. Sometimes, more than one type of load will be applied simultaneously or the amount and direction of the load may vary.

Variable loads cannot be used for life calculations of linear guides as they are. Therefore, it is necessary to use an applied hypothetical constant load that would generate a fatigue life equivalent to the actual fatigue life. This is called the dynamic equivalent load. To calculate dynamic equivalent load, use the values provided in Table 7.

Fig. 9 Direction of load

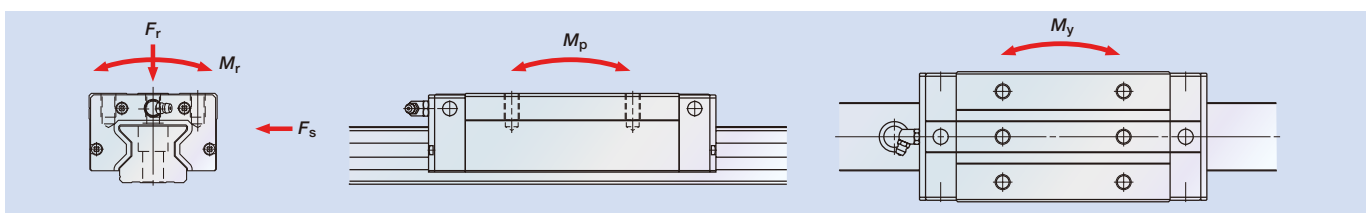

High-Rigidity Series: RA/RB Model Roller Guides

Table 7 Loads by arrangement of linear guide

Pattern	Arrangement of linear guide	Loads necessary to calculate dynamic equivalent load					Dynamic equivalent load
		Load		Moment load			
		Up/down (vertical)	Right/left (lateral)	Rolling	Pitching	Yawing	
1		F_r	F_s	M_r	M_p	M_y	$F_r = F_r$ $F_{se} = F_s \cdot \tan \alpha$ $F_{re} = \varepsilon_r \cdot M_r$ $F_{pe} = \varepsilon_p \cdot M_p$ $F_{ye} = \varepsilon_y \cdot M_y$ α : Contact angle (=45°) Dynamic equivalent coefficient ε_r : Rolling direction ε_p : Pitching direction ε_y : Yawing direction
2		F_r	F_s	M_r			
3		F_r	F_s		M_p	M_y	
4		F_r	F_s				

After obtaining the dynamic equivalent coefficient in Table 8 or 9, the full dynamic equivalent load can be obtained using the appropriate equation below as determined by the magnitude of the load:

- When F_r is the largest load: $F_e = F_r + 0.5F_{se} + 0.5F_{re} + 0.5F_{pe} + 0.5F_{ye}$
- When F_{se} is the largest load: $F_e = 0.5F_r + F_{se} + 0.5F_{re} + 0.5F_{pe} + 0.5F_{ye}$
- When F_{re} is the largest load: $F_e = 0.5F_r + 0.5F_{se} + F_{re} + 0.5F_{pe} + 0.5F_{ye}$
- When F_{pe} is the largest load: $F_e = 0.5F_r + 0.5F_{se} + 0.5F_{re} + F_{pe} + 0.5F_{ye}$
- When F_{ye} is the largest load: $F_e = 0.5F_r + 0.5F_{se} + 0.5F_{re} + 0.5F_{pe} + F_{ye}$

The values for dynamic equivalent load in the formulas above should be absolute values that disregard load directions.

Table 8 RA model: Dynamic equivalent coefficient

Model No.	Dynamic equivalent coefficient (1/m)		
	ε_r	ε_p	ε_y
RA15 High load type	105	95	95
RA15 Super-high load type	105	70	70
RA20 High load type	79	74	74
RA20 Super-high load type	79	55	55
RA25 High load type	71	64	64
RA25 Super-high load type	71	50	50
RA30 High load type	56	58	58
RA30 Super-high load type	56	44	44
RA35 High load type	46	52	52
RA35 Super-high load type	46	39	39
RA45 High load type	37	40	40
RA45 Super-high load type	37	30	30
RA55 High load type	32	33	33
RA55 Super-high load type	32	24	24
RA65 High load type	26	28	28
RA65 Super-high load type	26	19	19

Table 9 RB model: Dynamic equivalent coefficient

Model No.	Dynamic equivalent coefficient (1/m)		
	ε_r	ε_p	ε_y
RB30 High load type	56	58	58
RB30 Super-high load type	56	44	44
RB35 High load type	46	52	52
RB35 Super-high load type	46	39	39
RB45 High load type	37	40	40
RB45 Super-high load type	37	30	30
RB55 High load type	32	33	33
RB55 Super-high load type	32	24	24
RB65 High load type	26	28	28
RB65 Super-high load type	26	19	19

5. Lubrication Specifications

(1) Types of lubrication accessories

- Fig. 12 and Tables 11.1 and 11.2 show details on grease fittings and tube fittings.

(2) Mounting positions for lubrication accessories

- The standard position for grease fittings and tube fittings is on the end face of the roller slide. We can mount them on the side of the end cap as an option (Fig. 10). Please consult NSK to install grease or tube fittings to the roller slide body or to the side of an end cap.
- A lubrication hole can also be provided on top of the end cap. In this case, an O ring will be necessary. Fig. 11 and Tables 10.1-10.3 show mounting positions. Some AN/BN slides require spacers, which are available from NSK.
- When using a piping unit with a thread of $M6 \times 1$, a connector is required to connect the piping unit to a grease fitting mounting hole with $M6 \times 0.75$. Connectors are available from NSK.

(3) Oil lubrication precautions

- When oil lubrication is used, the oil may not reach the rolling surface under some roller slide mounting conditions (upside down, wall mountings, etc.) Please consult with NSK before use in these situations.
- When using an oil mist lubricating system, please confirm that a sufficient amount of oil reaches each outlet port.

Fig. 10 Mounting positions for lubrication accessories

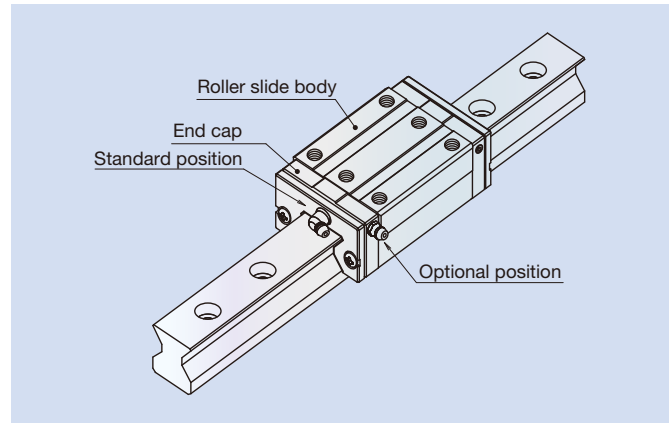

Fig. 11 Top and side lubrication hole positions

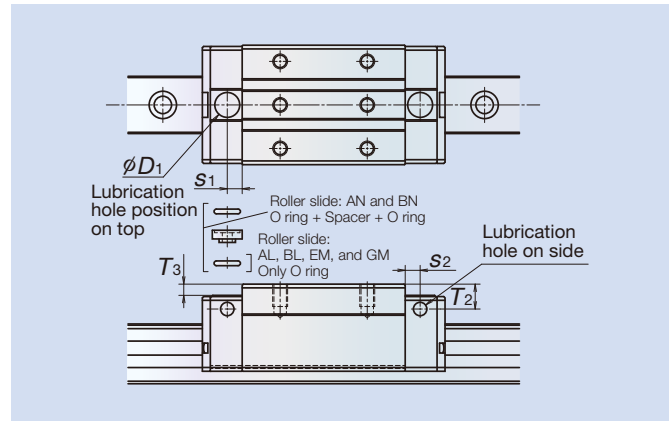

Table 10.1 RA model: Top and side lubrication hole positions

Unit: mm

Model No.	Roller slide shape code	Grease fitting size	s_2	T_2	O ring (JIS)	Spacer	D_1	s_1	T_3
RA15	AN, BN	$\phi 3$	4	7	P5	Necessary	8.2	4.4	4.2
RA20		$\phi 3$	4	4	P6	-	9.2	5.4	0.2
RA25		M6×0.75	6	10	P7	Necessary	10	6	4.5
RA30		M6×0.75	5	10	P7+P5	Necessary	10.4	6	3.5
RA35		M6×0.75	5.5	15	P7+P5	Necessary	10.4	7	7.4
RA45		Rc 1/8	7.2	20	P7+P5	Necessary	10.4	7.2	10.4
RA55		Rc 1/8	7.2	21	P7+P5	Necessary	10.4	7.2	10.4
RA65		Rc 1/8	7.2	19	P7	-	10.4	7.2	0.4

Note: Grease fittings and tube fittings cannot be mounted on the top of the end cap.

Table 10.2 RA model: Top and side lubrication hole positions

Unit: mm

Model No.	Roller slide shape code	Grease fitting size	s_2	T_2	O ring (JIS)	D_1	s_1	T_3
RA15	AL, BL, EM, GM	$\phi 3$	4	3	P5	8.2	4.4	0.2
RA20	EM, GM	$\phi 3$	4	4	P6	9.2	5.4	0.2
RA25	AL, BL, EM, GM	M6×0.75	6	6	P7	10	6	0.5
RA30		M6×0.75	5	7	P7	10.4	6	0.5
RA35		M6×0.75	5.5	8	P7	10.4	7	0.4
RA45		Rc 1/8	7.2	10	P7	10.4	7.2	0.4
RA55		Rc 1/8	7.2	11	P7	10.4	7.2	0.4
RA65	EM, GM	Rc 1/8	7.2	19	P7	10.4	7.2	0.4

Note: Grease fittings and tube fittings cannot be mounted on the top of the end cap.

High-Rigidity Series: RA/RB Model Roller Guides

Table 10.3 RB model: Top and side lubrication hole positions

Unit: mm

Model No.	Grease fitting size	s_2	T_2	O ring (JIS)	D_1	s_1	T_3
RB30	M6x0.75	5	6.5	P7	10.4	6	0.5
RB35	M6x0.75	5.5	6.5	P7	10.4	7	0.4
RB45	M6x0.75	7.2	6.5	P7	10.4	7.2	0.4
RB55	M6x0.75	7.2	8	P7	10.4	7.2	0.4
RB65	M6x0.75	7.2	10	P7	10.4	7.2	0.4

Note: Grease fittings and tube fittings cannot be mounted on the top of the end cap.

Table 11.1 RA model: Lubrication accessory thread length

Unit: mm

Model No.	Dust-resistant specification	Dimension L		
		Grease fitting / Drive-in type	Tube fitting	
			SF type	LF type
RA15	Standard	5	-	-
	With NSK K1	10	-	-
	Double seal	8	-	-
	Protector	8	-	-
RA20	Standard	5	-	-
	With NSK K1	10	-	-
	Double seal	8	-	-
	Protector	10	-	-
RA25	Standard	5	5	5
	With NSK K1	12	12	12
	Double seal	10	9	9
	Protector	10	9	9
RA30	Standard	5	6	6
	With NSK K1	14	14	15
	Double seal	12	12	11
	Protector	12	10	11
RA35	Standard	5	6	6
	With NSK K1	14	14	15
	Double seal	12	12	11
	Protector	12	10	11
RA45	Standard	8	13.5	17
	With NSK K1	18	20	21.5
	Double seal	14	16	17
	Protector	14	16	17
RA55	Standard	8	13.5	17
	With NSK K1	18	20	21.5
	Double seal	14	16	17
	Protector	14	16	17
RA65	Standard	8	13.5	17
	With NSK K1	20	20	20
	Double seal	14	18	17
	Protector	14	16	17

Table 11.2 RB model: Lubrication accessory thread length

Unit: mm

Model No.	Dust-resistant specification	Dimension L		
		Grease fitting / Drive-in type	Tube fitting	
			SF type	LF type
RB30	Standard	5	-	-
	With NSK K1	10	-	-
	Double seal	8	-	-
	Protector	8	-	-
RB35	Standard	5	5	5
	With NSK K1	14	15	16
	Double seal	12	12	12
	Protector	12	12	12
RB45	Standard	5	5	5
	With NSK K1	14	15	16
	Double seal	12	12	12
	Protector	12	12	12
RB55	Standard	8	13.5	17
	With NSK K1	18	20	21.5
	Double seal	14	16	17
	Protector	14	16	17
RB65	Standard	8	13.5	17
	With NSK K1	20	20	20
	Double seal	14	18	17
	Protector	14	16	17

Fig.12 Grease fittings and tube fittings

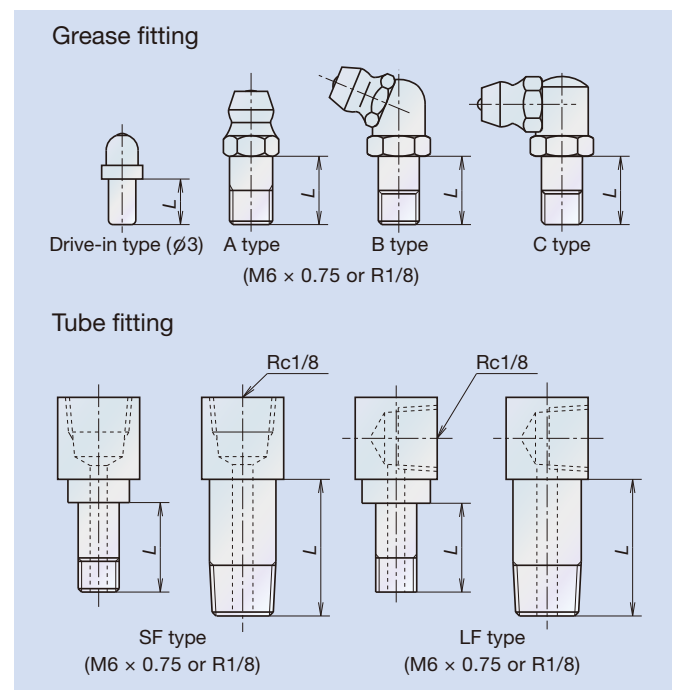

6. Dust-resistant specifications

(1) Standard specification

RA and RB models are equipped with end, inner¹⁾ and bottom seals to prevent foreign matter from entering the inside of the roller slide. Under normal applications, RA and RB models can be used without modification. For severe usage conditions, optional rail covers are available. Contact NSK for information on how to mount the cover.

Fig. 13 View of roller slide equipped with dust-resistant parts

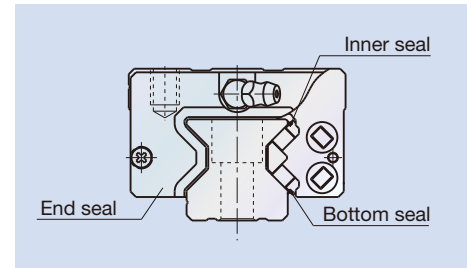

Table 12 Optional parts for dust resistance

Name	Purpose
NSK K1 lubrication unit	Made of oil impregnated resin. Enhances lubricating functions.
Double seal	Combines two end seals for enhanced seal effectiveness.
Protector	Protects the end seal from hot and hard contaminants.
Rail cap	Prevents foreign matter, such as swarf generated in cutting, from clogging the rail-mounting holes.
Rail cover ²⁾	Covers the rail top surface, and prevents foreign matter, such as cutting dust, from collecting in the rail mounting holes.

1) Inner seals for models RA15 and RA20 are available as an option. 2) Rail covers are available for models RA25 to RA65.

Fig. 14 Rail cover



(2) NSK K1™ lubrication unit

Tables 13 and 14 show the dimensions of linear guides equipped with the NSK K1 lubrication unit.

Table 13 RA Model: Slide lengths with NSK K1

Unit: mm

Model No.	Roller slide length	Roller slide shape code	Standard roller slide length	Roller slide length with two NSK K1 installed L	Thickness of single NSK K1 V ₁	Protrusion of grease fitting N
RA15	Standard	AN, AL, EM	70	79	4.5	(3)
	Long	BN, BL, GM	85.4	94.4		
RA20	Standard	AN, EM	86.5	95.5	4.5	(3)
	Long	BN, GM	106.3	115.3		
RA25	Standard	AN, AL, EM	97.5	107.5	5	(11)
	Long	BN, BL, GM	115.5	125.5		
RA30	Standard	AN, AL, EM	110.8	122.8	6	(11)
	Long	BN, BL, GM	135.4	147.4		
RA35	Standard	AN, AL, EM	123.8	136.8	6.5	(11)
	Long	BN, BL, GM	152	165		
RA45	Standard	AN, AL, EM	154	168	7	(14)
	Long	BN, BL, GM	190	204		
RA55	Standard	AN, AL, EM	184	198	7	(14)
	Long	BN, BL, GM	234	248		
RA65	Standard	AN, EM	228.4	243.4	7.5	(14)
	Long	BN, GM	302.5	317.5		

Note: Roller slide length when equipped with NSK K1 = (standard roller slide length) + (V₁ thickness of single NSK K1 unit) × (number of K1 units).

Fig. 15 Slide with NSK K1

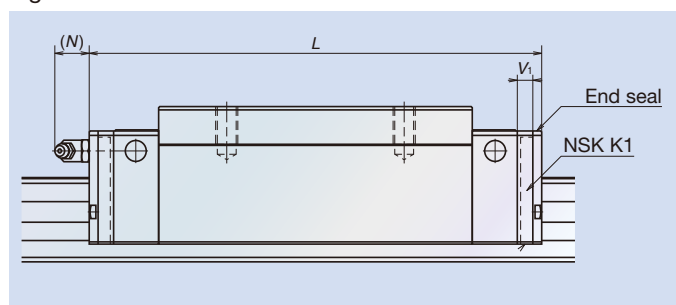

High-Rigidity Series: RA/RB Model Roller Guides

Table 14 RB Model: Slide lengths with NSK K1

Unit: mm

Model No.	Roller slide length	Roller slide shape code	Standard roller slide length	Roller slide length with two NSK K1 installed L	Thickness of single NSK K1 V_1	Protrusion of grease fitting N
RB30	Standard	AL, EM	110.8	122.8	6	(3)
	Long	BL, GM	135.4	147.4		
RB35	Standard	AL, EM	123.8	136.8	6.5	(11)
	Long	BL, GM	152	165		
RB45	Standard	AL, EM	154	168	7	(11)
	Long	BL, GM	190	204		
RB55	Standard	AL, TL, EM	184	198	7	(14)
	Long	BL, UL, GM	234	248		
RB65	Standard	AL, EM	228.4	243.4	7.5	(14)
	Long	BL, UL, GM	302.5	317.5		

Note: Roller slide length when equipped with NSK K1 = (standard roller slide length) + (V_1 thickness of single NSK K1 unit) × (number of K1 units).

(3) Double seal and protector

Double seals and protectors for RA/RB models can only be installed before shipping from the factory. Tables 15 and 16 show the increased thickness of end seals and protectors.

Fig. 16 Slide with end seal/protector

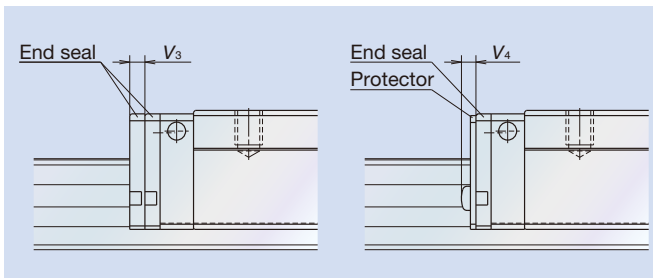

Table 15 Increased thickness of RA model options Unit: mm

Model No.	Thickness of end seal V_3	Thickness of protector V_4
RA15	3	2.7
RA20	3	3.3
RA25	3.2	3.3
RA30	3.4	3.6
RA35	3.4	3.6
RA45	4	4.2
RA55	4	4.2
RA65	5	5.5

Table 16 Increased thickness of RB model options Unit: mm

Model No.	Thickness of end seal V_3	Thickness of protector V_4
RB30	3.4	3.6
RB35	3.4	3.6
RB45	4	4.2
RB55	4	4.2
RB65	5	5.5

(4) Rail cover

Use a cover bracket to fix the rail cover when installing. Fig. 17 shows cover bracket dimensions. The protrusion from the end of the rail will be:

Inside: 10.5 mm or less

Outside: 4 mm or less (models RA25 to RA65)

Please confirm the stroke and space at the rail end in your machine.

Table 17 shows rail height when a rail cover is installed.

Fig. 17 End configuration of rail equipped with rail cover

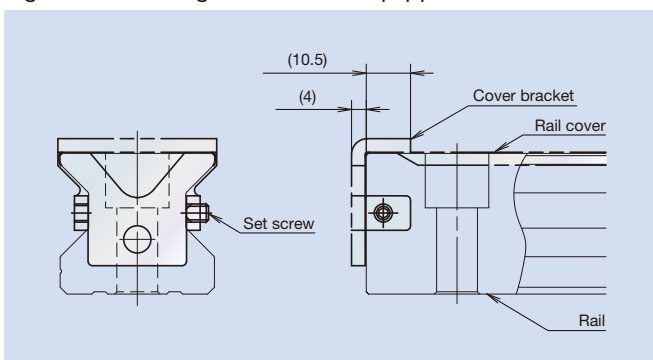

Table 17 Height of rails equipped with rail cover Unit: mm

Model No.	Standard rail height H_1	Rail height installed with rail cover
RA25	24	24.2
RA30	28	28.2
RA35	31	31.25
RA45	38	38.3
RA55	43.5	43.8
RA65	55	55.3

(5) Caps to plug rail mounting bolt holes

Bolt sizes for rail mounting and cap reference numbers are shown in Tables 18 and 19.

Table 18 RA model: Caps for rail mounting holes

Model No.	Bolt to secure rail	Cap reference No.	Quantity/case
RA15	M4	LG-CAP/M4	20
RA20	M5	LG-CAP/M5	
RA25	M6	LG-CAP/M6	
RA30, RA35	M8	LG-CAP/M8	
RA45	M12	LG-CAP/M12	
RA55	M14	LG-CAP/M14	
RA65	M16	LG-CAP/M16	

Table 19 RB model: Caps for rail mounting holes

Model No.	Bolt to secure rail	Cap reference No.	Quantity/case
RB30, RB35	M8	LG-CAP/M8	20
RB45	M12	LG-CAP/M12	
RB55	M14	LG-CAP/M14	
RB65	M16	LG-CAP/M16	

(6) Bellows

Bellows are available for the RA model.

Installation of bellows

Fixing to the roller slide

Remove the two machine screws that secure the end seal. (For RA15, hold the end cap by hand or the end cap may detach from the slide and the rollers may fall out.)

Place a spacer ring on the mounting hole of the end seal and fasten the mounting plate at the end of the bellows using a slightly longer machine screw. (For RA15, place a spacer plate between the end seal and the mounting plate at the end of the bellows.)

Fixing to the rail

First, make tap holes on the rail end surface. Fix the bellows mounting plate to the rail end surface with machine screws through these tap holes. NSK processes tap holes on the rail end surface when a linear guide and bellows are ordered as a set.

Calculating bellows length

The formulas for calculating the length of end bellows are as follows.

Stroke

$$S_t = L_{\max} - L_{\min}$$

Length when stretched to the maximum

$$L_{\max} = f_b \cdot P \times \text{Number of folds}$$

Length when contracted to the minimum

$$L_{\min} = 2.5 \times \text{Number of folds} + 3$$

Values for f_b and P are shown in the bellows dimension table. Based on the above formulas, you may calculate the number of folds as follows:

$$\text{Number of folds} = \frac{S_t - 3}{f_b \cdot P - 2.5}$$

Round up the calculated value so that the number of folds will be $n + 0.5$ (n : a natural number).

Please contact NSK regarding the length of middle bellows.

If considering bellows for the RB model, please consult with NSK.

High-Rigidity Series: RA/RB Model Roller Guides

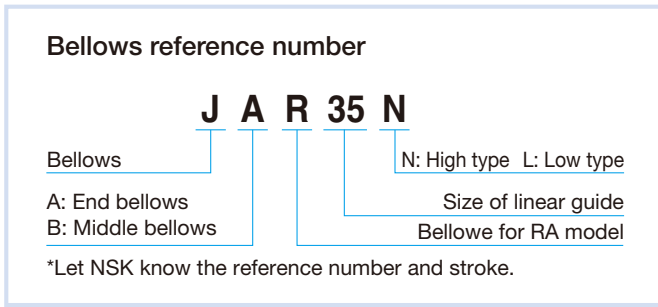

Fig. 18 Bellows dimensions

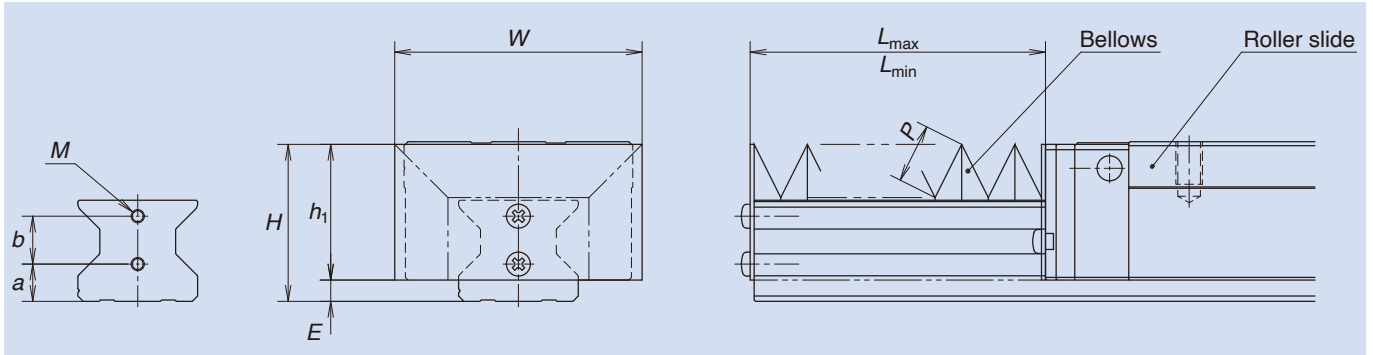

Table 20 Bellows dimensions

Unit: mm (excluding f_b)

Model No.	H	h_1	E	W	P	f_b	a	b	Tap $M \times$ depth
JAR15L	23.5	19.5	4	33	7	1.2	7	6.3	M3x5
JAR15N	27	23		39	10	1.3			
JAR20N	29	24	5	43	8	1.3	8.5	9	M3x5
JAR25L	35	30	5	55	10	1.3	8.5	12	M3x5
JAR25N	39	34		61	14	1.4			
JAR30L	41	34.5	6.5	60	12	1.3	11	12.5	M4x6
JAR30N	44	37.5		66	15	1.4			
JAR35L	47	40.5	6.5	72	15	1.4	11	15	M4x6
JAR35N	54	47.5		82	20	1.5			
JAR45L	59	51	8	93	20	1.5	14	18	M5x8
JAR45N	69	61		113	30	1.5			
JAR55L	69	60	9	101	20	1.5	15	22	M5x8
JAR55N	79	70		121	30	1.5			
JAR65N	89	76	13	131	30	1.5	21	26	M6x10

Note: f_b is a dimensionless number.

7. Maximum rail length

Tables 21 and 22 show rail length limits (maximum lengths) for a single rail in the RA/RB models; however, note that limits vary by accuracy grade.

Table 21 RA model: Rail length limits

Unit: mm

Size	RA15	RA20	RA25	RA30	RA35	RA45	RA55	RA65
Maximum length	2 000	3 000	3 900	3 900	3 900	3 650	3 600	3 600

Table 22 RB model: Rail length limits

Unit: mm

Size	RB30	RB35	RB45	RB55	RB65
Maximum length	3 900	3 900	3 650	3 600	3 600

Note: Rails can be butted if user requirements exceed the rail length shown in the table. Please consult NSK for details.

8. Installation

(1) Permissible mounting error

Improper mounting results in harmful effects such as shortened operating life, deterioration of motion accuracy, and friction variation.

NSK places a strong focus on operating life—we set permissible mounting error to values where the operating life will be calculated to exceed 10 000 km assuming the following conditions:

- The load per roller slide is 10% of basic dynamic load rating C.
- The rigidity of machine is infinite.

Permissible mounting error is shown in Table 23 using the representative error shown in Fig. 19.

Fig. 19 Permissible mounting error

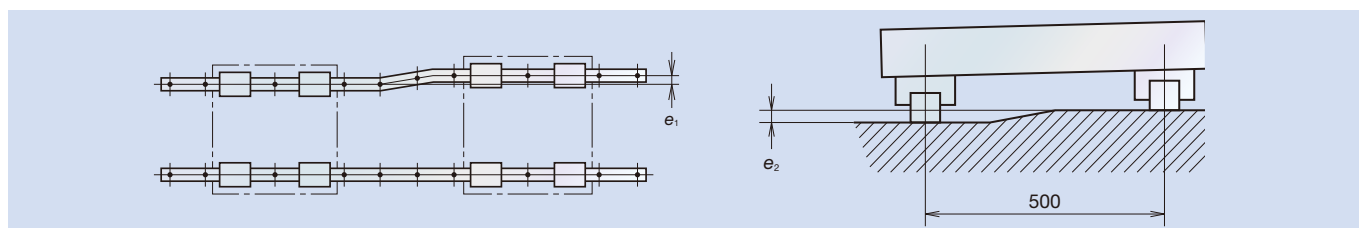

Table 23 RA model: Permissible mounting error

Unit: μm

Value	Preload	Model No.							
		RA15	RA20	RA25	RA30	RA35	RA45	RA55	RA65
Permissible values for parallelism error of two rails e_1	Z1, ZZ	7	10	14	18	21	27	31	49
	Z3, ZH	5	7	9	11	13	17	19	30
Permissible values for height error of two rails e_2	Z1, ZZ	290 μm /500mm							
	Z3, ZH	150 μm /500mm							

Table 24 RB model: Permissible mounting error

Unit: μm

Value	Preload	Model No.				
		RB30	RB35	RB45	RB55	RB65
Permissible values for parallelism error of two rails e_1	Z3	11	13	17	19	30
Permissible values for height error of two rails e_2	Z3	150 μm /500mm				

(2) Shoulder height and corner radius of mounting surface

Fig. 20 and Tables 25 and 26 show shoulder height and corner radius of the mounting surface when the rail or slide is pressed against the shoulder of the machine base or table (the raised section of the mounting surface) and fixed horizontally.

Fig. 20 Datum faces of roller guide and shoulder

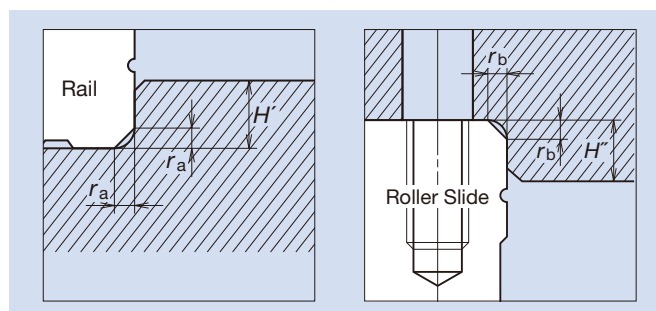

High-Rigidity Series: RA/RB Model Roller Guides

Table 25 RA model: Shoulder height and corner radius of the mounting surface Unit: mm

Model No.	Shoulder height		Corner radius (maximum)	
	H'	H''	r_a	r_b
RA15	3	4	0.5	0.5
RA20	4	5	0.5	0.5
RA25	4	5	0.5	1
RA30	5	6	1	1
RA35	5	6	1	1
RA45	6	8	1.5	1
RA55	7	10	1.5	1.5
RA65	11	11	1.5	1.5

Table 26 RB model: Shoulder height and corner radius of the mounting surface Unit: mm

Model No.	Shoulder height		Corner radius (maximum)	
	H'	H''	r_a	r_b
RB30	5	6	1	1
RB35	5	6	1	1
RB45	6	8	1.5	1
RB55	7	10	1.5	1.5
RB65	8	11	1.5	1.5

Handling Precautions

- ① Operating temperature limits should normally be less than 80°C.
- ② If using NSK K1™, service temperature should not exceed 50°C (or 80°C momentarily). Make sure the unit does not come in contact with organic solvents that can be used for degreasing. Do not place the unit in a location exposed to white kerosene or rust prevention oil containing white kerosene.
- ③ To transfer a slide onto/from a rail, please note the following:
 - Do not remove the roller slide from the rail unless absolutely necessary.
 - When moving the roller slide onto or off of a rail, use the provided provisional rail to prevent dents and scratches on the raceways from excessive force and to prevent the rollers from falling out.
 - Ensure that the bottom and side of the provisional rail are aligned to the rail that the slide will be transferred onto/from and move the slide while butting the end faces of the rails.
 - Use a clean provisional rail. Do not use with a rail that is contaminated with foreign matter or that uses a different type of lubricant.

RA Model: Dimension Tables

Square type (tapped mounting holes)

RA-AN (High load/standard), RA-BN (Super-high load/long)

(1) Reference number for preloaded assembly

RA 35 1000 AN C 2 - P6 3**

Model name	RA 35 1000 AN C 2 -** P6 3	Preload code	3
Size	35	1: Z1, 3: Z3, Z: ZZ, H: ZH	
Rail length (mm)	1000	Accuracy code	P6
Roller slide shape code: AN, BN	AN	(Without NSK K1): P3, P4, P5, P6, PH (With NSK K1): K3, K4, K5, K6, KH	
Material/surface treatment code	C	Design serial number	-**
C: Special high carbon steel (NSK standard)		Added to the reference number.	
		Number of roller slides per rail	2

(2) Reference number for interchangeable type

RAA 35 AN PH H -F

Roller slide	RAA 35 AN PH H -F	Option code	-F
Interchangeable roller slide model code	RAA 35 AN PH H -F	No code: No surface treatment -F: Fluoride low temperature chrome plating -C: No surface treatment + Rail cover -CF: Fluoride low temperature chrome plating + Rail cover	
Size	35	Preload code	H
Roller slide shape code: AN, BN	AN	Z: Slight preload, H: Medium preload	
		Accuracy code	PH
		PH, KH: High-precision grade interchangeable type	

Rail R1A 35 1000 L C N - PH Z**

Rail	R1A 35 1000 L C N -** PH Z	Preload code	Z
Interchangeable rail model code	R1A 35 1000 L C N -** PH Z	Z: Common for slight and medium preload	
Size	35	Accuracy code	PH
Rail length (mm)	1000	PH: High-precision grade interchangeable type	
Rail shape code: L	L	Design serial number	-**
L: Standard		Added to the reference number.	
Material/surface treatment code	C	*Butting rail specification	N
		N: Non-butting, L: Butting specification	
		*Please consult with NSK for butting rail specifications.	

Model No.	Assembly			Roller slide											Width W ₁	Height H ₁
	Height H	E	W ₂	Width W	Length L	Mounting hole			L ₁	K	T	Grease fitting				
						B	J	M × pitch × ℓ				Hole size	T ₁	N		
RA15AN RA15BN	28	4	9.5	34	70 85.4	26	26	M4×0.7×6	44.8 60.2	24	8	φ3	8	3	15	16.3
RA20AN RA20BN	30	5	12	44	86.5 106.3	32	36 50	M5×0.8×6	57.5 77.3	25	12	φ3	4	3	20	20.8
RA25AN RA25BN	40	5	12.5	48	97.5 115.5	35	35 50	M6×1×9	65.5 83.5	35	12	M6×0.75	10	11	23	24
RA30AN RA30BN	45	6.5	16	60	110.8 135.4	40	40 60	M8×1.25×11	74 98.6	38.5	14	M6×0.75	10	11	28	28
RA35AN RA35BN	55	6.5	18	70	123.8 152	50	50 72	M8×1.25×12	83.2 111.4	48.5	15	M6×0.75	15	11	34	31
RA45AN RA45BN	70	8	20.5	86	154 190	60	60 80	M10×1.5×17	105.4 141.4	62	17	R _C 1/8	20	14	45	38
RA55AN RA55BN	80	9	23.5	100	184 234	75	75 95	M12×1.75×18	128 178	71	18	R _C 1/8	21	14	53	43.5
RA65AN RA65BN	90	13	31.5	126	228.4 302.5	76	70 120	M16×2×20	155.4 229.5	77	22	R _C 1/8	19	14	63	55

Notes: 1) Select either the standard dimension for pitch *F* as shown without parentheses, or the semi-standard dimension as shown inside parentheses. If not specified, the standard dimension for *F* will be applied.

High-Rigidity Series: RA/RB Model Roller Guides

Assembly

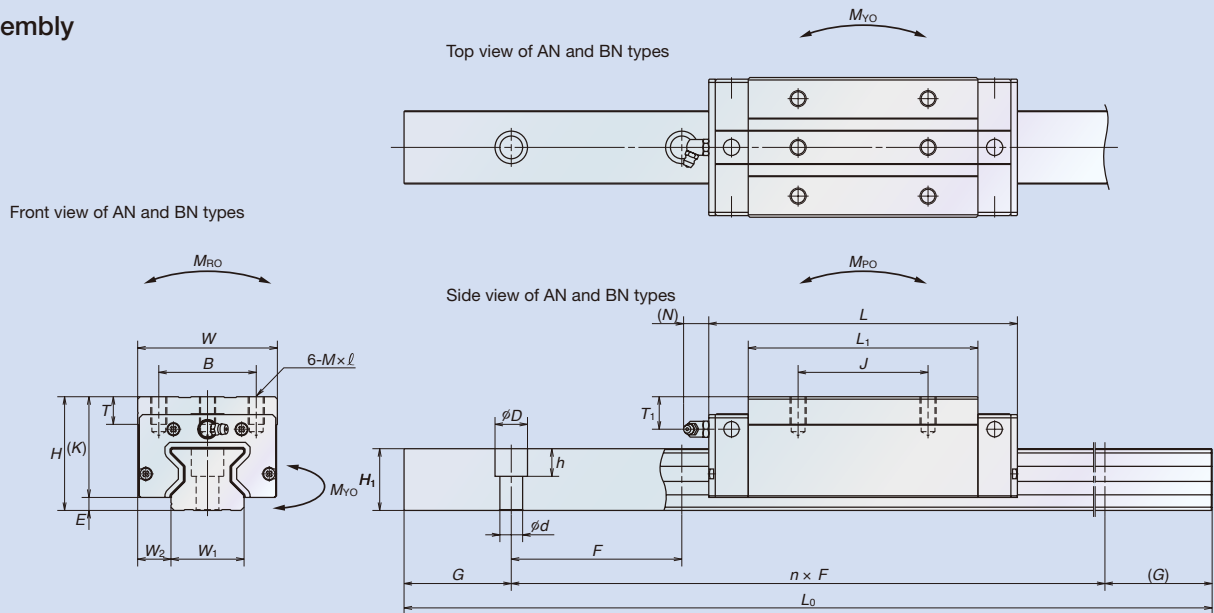

Interchangeable roller slide

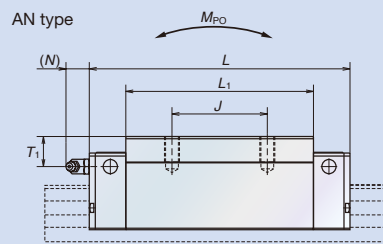

Interchangeable rail

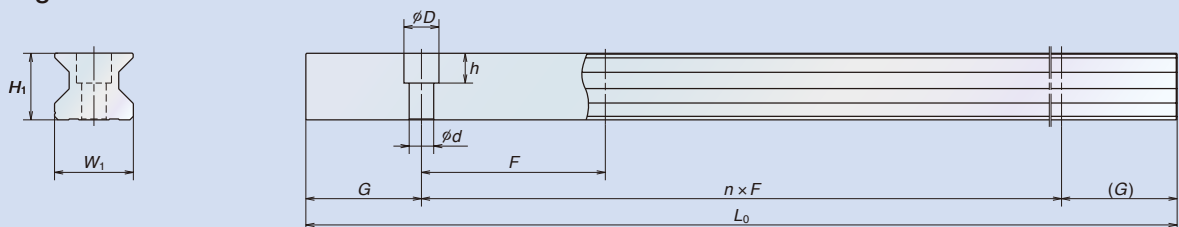

Unit: mm

Rail				Basic load ratings								Weight	
Pitch <i>F</i>	Mounting bolt hole <i>d</i> × <i>D</i> × <i>h</i>	<i>G</i> (reference)	Maximum length <i>L</i> _{0max}	3) Dynamic		Static <i>C</i> ₀ (N)	<i>M</i> _{R0}	Static moment (N·m)				Roller slide (kg)	Rail (kg/m)
				[50km] <i>C</i> ₅₀ (N)	[100km] <i>C</i> ₁₀₀ (N)			<i>M</i> _{P0}		<i>M</i> _{Y0}			
						One slide		Two slides	One slide	Two slides			
60 (30)	4.5×7.5×5.3	20	2 000	12 600 16 000	10 300 13 000	27 500 37 000	260 350	210 375	1 320 2 130	210 375	1 320 2 130	0.21 0.30	1.6
60 (30)	6×9.5×8.5	20	3 000	23 600 29 500	19 200 24 000	52 500 70 000	665 890	505 900	3 100 5 000	505 900	3 100 5 000	0.38 0.50	2.6
30 (60)	7×11×9	20	3 900	36 000 43 500	29 200 35 400	72 700 92 900	970 1 240	760 1 240	4 850 7 200	760 1 240	4 850 7 200	0.60 0.91	3.4
40 (80)	9×14×12	20	3 900	47 800 58 500	38 900 47 600	93 500 121 000	1 670 2 170	1 140 1 950	7 100 11 500	1 140 1 950	7 100 11 500	1.0 1.3	4.9
40 (80)	9×14×12	20	3 900	65 500 82 900	53 300 67 400	129 000 175 000	2 810 3 810	1 800 3 250	11 000 17 800	1 800 3 250	11 000 17 800	1.6 2.1	6.8
52.5 (105)	14×20×17	22.5	3 650	114 000 143 000	92 800 116 000	229 000 305 000	6 180 8 240	4 080 7 150	24 000 39 000	4 080 7 150	24 000 39 000	3.0 4.1	10.9
60 (120)	16×23×20	30	3 600	159 000 207 000	129 000 168 000	330 000 462 000	10 200 14 300	7 060 13 600	41 000 72 000	7 060 13 600	41 000 72 000	4.9 6.7	14.6
75 (150)	18×26×22	35	3 600	259 000 355 000	210 000 288 000	504 000 756 000	19 200 28 700	12 700 28 600	78 500 153 000	12 700 28 600	78 500 153 000	9.3 12.2	22.0

2) The interchangeable type is available for models RA25 to RA65.

3) Basic load ratings comply with ISO standards (ISO 14728-1, 14728-2).

*C*₅₀: Basic dynamic load rating for 50 km rated fatigue life

*C*₁₀₀: Basic dynamic load rating for 100 km rated fatigue life

RA Model: Dimension Tables

Low profile type (tapped mounting holes)

RA-AL (High load/standard), RA-BL (Super-high load/long)

(1) Reference number for preloaded assembly

RA 35 1000 AL C 2 - P6 3**

Model name	RA	35	1000	AL	C	2	-**	P6	3	Preload code 1: Z1, 3: Z3, Z: ZZ, H: ZH
Size										Accuracy code (Without NSK K1): P3, P4, P5, P6, PH (With NSK K1): K3, K4, K5, K6, KH
Rail length (mm)										Design serial number Added to the reference number.
Roller slide shape code: AL, BL										Number of roller slides per rail
Material/surface treatment code C: Special high carbon steel (NSK standard)										

(2) Reference number for interchangeable type

RAA 35 AL PH H -F

Roller slide	RAA	35	AL	PH	H	-F	Option code No code: No surface treatment -F: Fluoride low temperature chrome plating -C: No surface treatment + Rail cover -CF: Fluoride low temperature chrome plating + Rail cover
Interchangeable roller slide model code RAA: RA Model interchangeable roller slide							Preload code Z: Slight preload, H: Medium preload
Size							Accuracy code PH, KH: High-precision grade interchangeable type
Roller slide shape code: AL, BL							

Rail R1A 35 1000 L C N - PH Z**

Rail	R1A	35	1000	L	C	N	-**	PH	Z	Preload code Z: Common for slight and medium preload
Interchangeable rail model code R1A: RA Model interchangeable rail										Accuracy code PH: High-precision grade interchangeable type
Size										Design serial number Added to the reference number.
Rail length (mm)										*Butting rail specification N: Non-butting, L: Butting specification
Rail shape code: L L: Standard										*Please consult with NSK for butting rail specifications.
Material/surface treatment code										

Model No.	Assembly			Roller slide											Width W ₁	Height H ₁
	Height H	E	W ₂	Width W	Length L	Mounting hole			L ₁	K	T	Grease fitting				
						B	J	M × pitch × ℓ				Hole size	T ₁	N		
RA15AL RA15BL	24	4	9.5	34	70 85.4	26	26	M4×0.7×5.5	44.8 60.2	20	8	φ3	4	3	15	16.3
RA25AL RA25BL	36	5	12.5	48	97.5 115.5	35	35 50	M6×1×8	65.5 83.5	31	12	M6×0.75	6	11	23	24
RA30AL RA30BL	42	6.5	16	60	110.8 135.4	40	40 60	M8×1.25×11	74 98.6	35.5	14	M6×0.75	7	11	28	28
RA35AL RA35BL	48	6.5	18	70	123.8 152	50	50 72	M8×1.25×12	83.2 111.4	41.5	15	M6×0.75	8	11	34	31
RA45AL RA45BL	60	8	20.5	86	154 190	60	60 80	M10×1.5×16	105.4 141.4	52	17	R _C 1/8	10	14	45	38
RA55AL RA55BL	70	9	23.5	100	184 234	75	75 95	M12×1.75×18	128 178	61	18	R _C 1/8	11	14	53	43.5

Notes: 1) Select either the standard dimension for pitch *F* as shown without parentheses, or the semi-standard dimension as shown inside parentheses.
If not specified, the standard dimension for *F* will be applied.

High-Rigidity Series: RA/RB Model Roller Guides

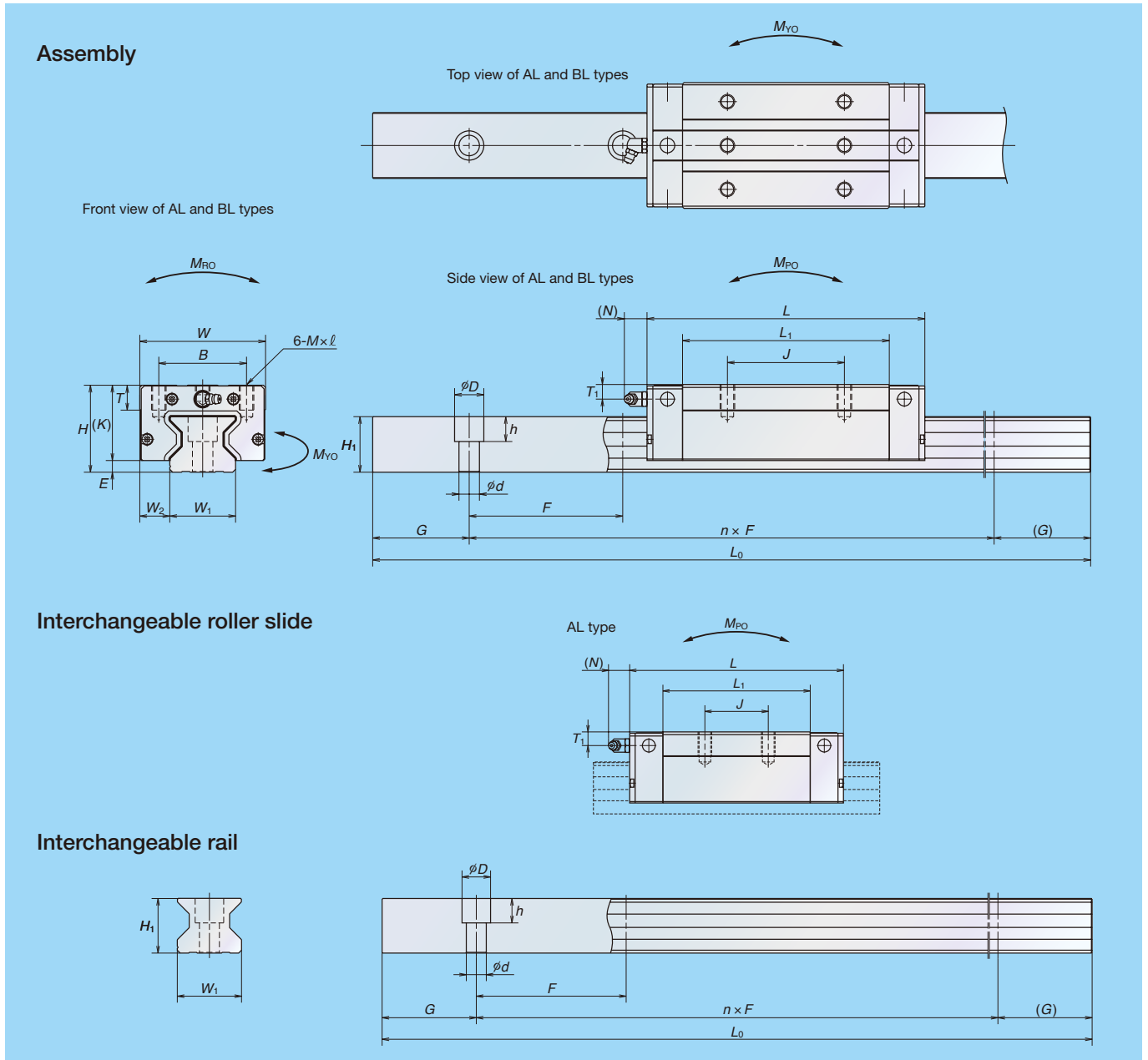

Unit: mm

Rail				Basic load ratings								Weight	
Pitch <i>F</i>	Mounting bolt hole <i>d</i> × <i>D</i> × <i>h</i>	<i>G</i> (reference)	Maximum length <i>L</i> _{0max}	3) Dynamic		Static <i>C</i> ₀ (N)	<i>M</i> _{R0}	Static moment (N·m)				Roller slide (kg)	Rail (kg/m)
				[50km] <i>C</i> ₅₀ (N)	[100km] <i>C</i> ₁₀₀ (N)			<i>M</i> _{P0}		<i>M</i> _{Y0}			
								One slide	Two slides	One slide	Two slides		
60 (30)	4.5×7.5×5.3	20	2 000	12 600 16 000	10 300 13 000	27 500 37 000	260 350	210 375	1 320 2 130	210 375	1 320 2 130	0.17 0.25	1.6
30 (60)	7×11×9	20	3 900	36 000 43 500	29 200 35 400	72 700 92 900	970 1 240	760 1 240	4 850 7 200	760 1 240	4 850 7 200	0.45 0.80	3.4
40 (80)	9×14×12	20	3 900	47 800 58 500	38 900 47 600	93 500 121 000	1 670 2 170	1 140 1 950	7 100 11 500	1 140 1 950	7 100 11 500	0.85 1.1	4.9
40 (80)	9×14×12	20	3 900	65 500 82 900	53 300 67 400	129 000 175 000	2 810 3 810	1 800 3 250	11 000 17 800	1 800 3 250	11 000 17 800	1.2 1.7	6.8
52.5 (105)	14×20×17	22.5	3 650	114 000 143 000	92 800 116 000	229 000 305 000	6 180 8 240	4 080 7 150	24 000 39 000	4 080 7 150	24 000 39 000	2.5 3.4	10.9
60 (120)	16×23×20	30	3 600	159 000 207 000	129 000 168 000	330 000 462 000	10 200 14 300	7 060 13 600	41 000 72 000	7 060 13 600	41 000 72 000	4.1 5.7	14.6

2) The interchangeable type is available for models RA25 to RA65.

3) Basic load ratings comply with ISO standards (ISO 14728-1, 14728-2).

*C*₅₀: Basic dynamic load rating for 50 km rated fatigue life

*C*₁₀₀: Basic dynamic load rating for 100 km rated fatigue life

RA Model: Dimension Tables

Flanged type (for both tapped and bolt mounting holes) RA-EM (High load/standard), RA-GM (Super-high load/long)

(1) Reference number for preloaded assembly

RA 35 1000 EM C 2 - P6 3**

Model name	RA	35	1000	EM	C	2	-**	P6	3	Preload code 1: Z1, 3: Z3, Z: ZZ, H: ZH
Size										Accuracy code (Without NSK K1): P3, P4, P5, P6, PH (With NSK K1): K3, K4, K5, K6, KH
Rail length (mm)										Design serial number Added to the reference number.
Roller slide shape code: EM, GM										Number of roller slides per rail
Material/surface treatment code C: Special high carbon steel (NSK standard)										

(2) Reference number for interchangeable type

RAA 35 EM PH H -F

Roller slide	RAA	35	EM	PH	H	-F					Option code No code: No surface treatment -F: Fluoride low temperature chrome plating -C: No surface treatment + Rail cover -CF: Fluoride low temperature chrome plating + Rail cover
Interchangeable roller slide model code RAA: RA Model interchangeable roller slide										Preload code Z: Slight preload, H: Medium preload	
Size										Accuracy code PH, KH: High-precision grade interchangeable type	
Roller slide shape code: EM, GM											

Rail R1A 35 1000 L C N - PH Z**

Rail	R1A	35	1000	L	C	N	-**	PH	Z	Preload code Z: Common for slight and medium preload
Interchangeable rail model code R1A: RA Model interchangeable rail										Accuracy code PH: High-precision grade interchangeable type
Size										Design serial number Added to the reference number.
Rail length (mm)										*Butting rail specification N: Non-butting, L: Butting specification
Rail shape code: L L: Standard										*Please consult with NSK for butting rail specifications.
Material/surface treatment code										

Model No.	Assembly			Roller slide													
	Height	E	W ₂	Width	Length	Mounting hole					Q ₂	L ₁	K	T	Grease fitting		
						B	J	J ₂	M × pitch × l ₁ (l ₂)	Hole size					T ₁	N	
RA15EM RA15GM	24	4	16	47	70 85.4	38	30	26	M5×0.8×8.5 (6.5)	4.4	44.8 60.2	20	8	φ3	4	3	
RA20EM RA20GM	30	5	21.5	63	86.5 106.3	53	40	35	M6×1×9.5 (8)	5.3	57.5 77.3	25	10	φ3	4	3	
RA25EM RA25GM	36	5	23.5	70	97.5 115.5	57	45	40	M8×1.25×10 (11)	6.8	65.5 83.5	31	11	M6×0.75	6	11	
RA30EM RA30GM	42	6.5	31	90	110.8 135.4	72	52	44	M10×1.5×12 (12.5)	8.6	74 98.6	35.5	11	M6×0.75	7	11	
RA35EM RA35GM	48	6.5	33	100	123.8 152	82	62	52	M10×1.5×13 (7)	8.6	83.2 111.4	41.5	12	M6×0.75	8	11	
RA45EM RA45GM	60	8	37.5	120	154 190	100	80	60	M12×1.75×15 (10.5)	10.5	105.4 141.4	52	13	R _C 1/8	10	14	
RA55EM RA55GM	70	9	43.5	140	184 234	116	95	70	M14×2×18 (13)	12.5	128 178	61	15	R _C 1/8	11	14	
RA65EM RA65GM	90	13	53.5	170	228.4 302.5	142	110	82	M16×2×24 (18.5)	14.6	155.4 229.5	77	22	R _C 1/8	19	14	

Notes: 1) Select either the standard dimension for pitch *F* as shown without parentheses, or the semi-standard dimension as shown inside parentheses. If not specified, the standard dimension for *F* will be applied.

High-Rigidity Series: RA/RB Model Roller Guides

Assembly

Front view of EM and GM types

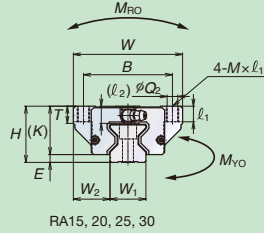

RA15, 20, 25, 30

Top view of EM and GM types

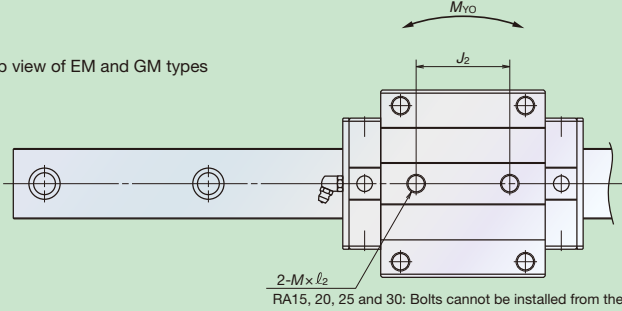

RA15, 20, 25 and 30: Bolts cannot be installed from the underside.

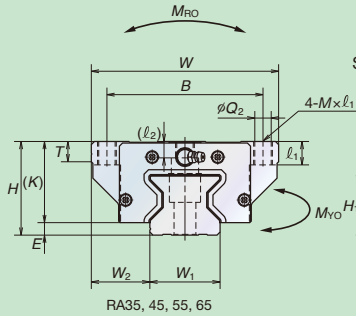

RA35, 45, 55, 65

Side view of EM and GM types

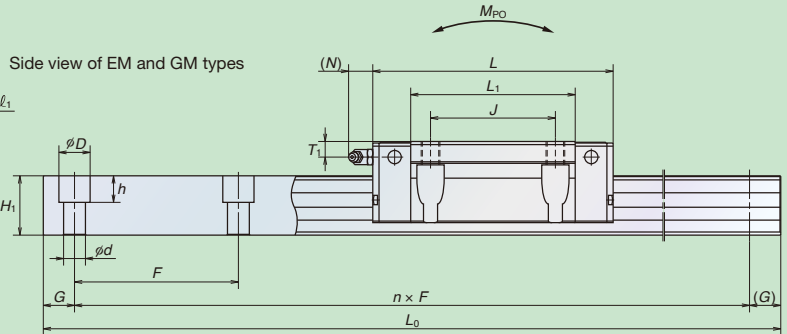

Interchangeable roller slide

EM type

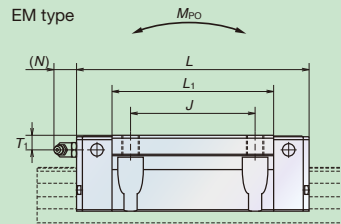

Interchangeable rail

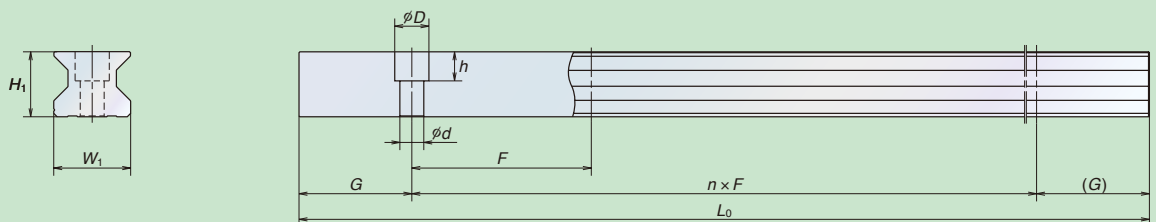

Unit: mm

Rail						Basic load ratings								Weight	
Width W_1	Height H_1	Pitch F	Mounting bolt hole $d \times D \times h$	G (reference)	Maximum length L_{0max}	3) Dynamic		Static C_0 (N)	M_{RO}	Static moment (N.m)				Roller slide (kg)	Rail (kg/m)
						[50km] C_{50} (N)	[100km] C_{100} (N)			M_{PO}		M_{YO}			
								One slide		Two slides	One slide	Two slides			
15	16.3	60 (30)	4.5×7.5×5.3	20	2 000	12 600 16 000	10 300 13 000	27 500 37 000	260 350	210 375	1 320 2 130	210 375	1 320 2 130	0.21 0.28	1.6
20	20.8	60 (30)	6×9.5×8.5	20	3 000	23 600 29 500	19 200 24 000	52 500 70 000	665 890	505 900	3 100 5 000	505 900	3 100 5 000	0.45 0.65	2.6
23	24	30 (60)	7×11×9	20	3 900	36 000 43 500	29 200 35 400	72 700 92 900	970 1 240	760 1 240	4 850 7 200	760 1 240	4 850 7 200	0.80 1.1	3.4
28	28	40 (80)	9×14×12	20	3 900	47 800 58 500	38 900 47 600	93 500 121 000	1 670 2 170	1 140 1 950	7 100 11 500	1 140 1 950	7 100 11 500	1.3 1.7	4.9
34	31	40 (80)	9×14×12	20	3 900	65 500 82 900	53 300 67 400	129 000 175 000	2 810 3 810	1 800 3 250	11 000 17 800	1 800 3 250	11 000 17 800	1.7 2.3	6.8
45	38	52.5 (105)	14×20×17	22.5	3 650	114 000 143 000	92 800 116 000	229 000 305 000	6 180 8 240	4 080 7 150	24 000 39 000	4 080 7 150	24 000 39 000	3.2 4.3	10.9
53	43.5	60 (120)	16×23×20	30	3 600	159 000 207 000	129 000 168 000	330 000 462 000	10 200 14 300	7 060 13 600	41 000 72 000	7 060 13 600	41 000 72 000	5.4 7.5	14.6
63	55	75 (150)	18×26×22	35	3 600	259 000 355 000	210 000 288 000	504 000 756 000	19 200 28 700	12 700 28 600	78 500 153 000	12 700 28 600	78 500 153 000	12.2 16.5	22.0

2) The interchangeable type is available for models RA25 to RA65.

3) Basic load ratings comply with ISO standards (ISO 14728-1, 14728-2).

C_{50} : Basic dynamic load rating for 50 km rated fatigue life

C_{100} : Basic dynamic load rating for 100 km rated fatigue life

RB Model: Dimension Tables

Low profile type (tapped mounting holes)

RB-AL·TL (High load/standard), RB-BL·UL (Super-high load/long)

Reference number for preloaded assembly

RB 35 1000 AL C 2 - P6 3**

Model name	RB	35	1000	AL	C	2	-**	P6	3	Preload code 3: Z3
Size										Accuracy code
Rail length (mm)										(Without NSK K1): P3, P4, P5, P6 (With NSK K1): K3, K4, K5, K6
Roller slide shape code: AL, TL, BL, UL										Design serial number Added to the reference number.
Material/surface treatment code C: Special high carbon steel (NSK standard)										Number of roller slides per rail

Model No.	Assembly			Roller slide											Width W_1	Height H_1	
	Height H	E	W_2	Width W	Length L	Mounting hole				L_1	K	T	Grease fitting				
						B	J	Number of holes	$M \times \text{pitch} \times \ell$				Hole size	T_1			N
RB30AL RB30BL	38	6.5	16	60	110.8 135.4	40	40 60	6 8	M8×1.25×7	74 98.6	31.5	14	φ3	5	2.6	28	28
RB35AL RB35BL	44	6.5	18	70	123.8 152	50	50 72	6 8	M8×1.25×8	83.2 111.4	37.5	15	M6×0.75	6.5	11	34	31
RB45AL RB45BL	52	8	20.5	86	154 190	60	60 80	6 8	M10×1.5×10	105.4 141.4	44	17	M6×0.75	6.5	14	45	38
RB55AL RB55TL RB55BL RB55UL	63	9	23.5	100	184	65 75	75	4	M12×1.75×12	128	54	18	R _C 1/8	8.5	14	53	43.5
234					65 75	95	6	178									
RB65AL RB65BL RB65UL	75	10	31.5	126	228.4	76	70	6	M16×2×16	155.4	65	22	R _C 1/8	10	14	63	52
302.5					110 120		229.5										

Notes: 1) Select either the standard dimension for pitch F as shown without parentheses, or the semi-standard dimension as shown inside parentheses. If not specified, the standard dimension for F will be applied.

High-Rigidity Series: RA/RB Model Roller Guides

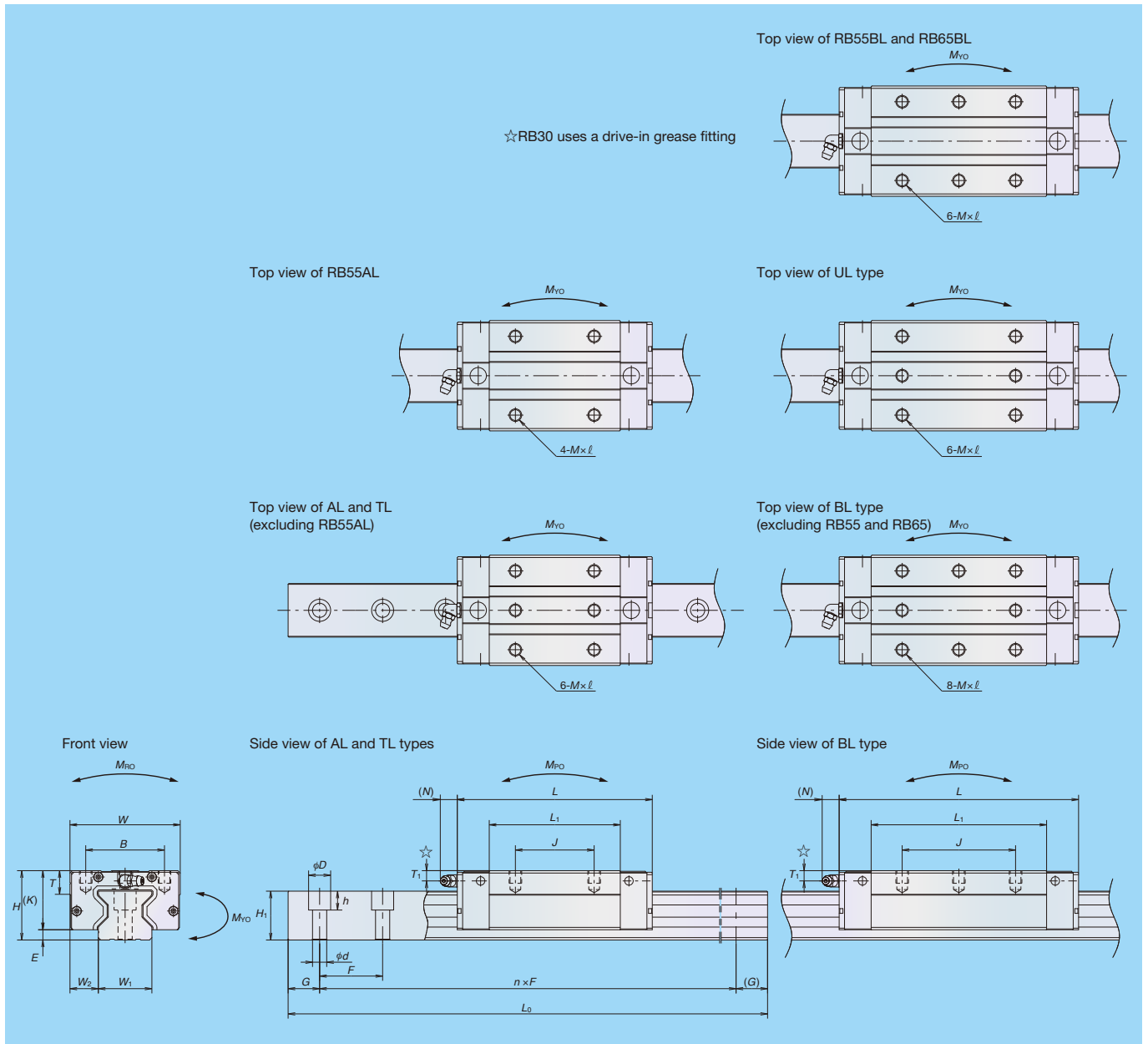

Unit: mm

Rail				Basic load ratings								Weight	
Pitch F	Mounting bolt hole d \times D \times h	G (reference)	Maximum length L _{0max}	2) Dynamic		Static C ₀ (N)	M _{R0}	Static moment (N·m)				Roller slide (kg)	Rail (kg/m)
				[50km] C ₅₀ (N)	[100km] C ₁₀₀ (N)			M _{P0}		M _{Y0}			
								One slide	Two slides	One slide	Two slides		
40 (80)	9 \times 14 \times 12	20	3 900	47 800	38 900	93 500	1 670	1 140	7 100	1 140	7 100	0.71	4.9
				58 500	47 600	121 000	2 170	1 950	11 500	1 950	11 500	0.91	
40 (80)	9 \times 14 \times 12	20	3 900	65 500	53 300	129 000	2 810	1 800	11 000	1 800	11 000	1.0	6.8
				82 900	67 400	175 000	3 810	3 250	17 800	3 250	17 800	1.5	
52.5 (105)	14 \times 20 \times 17	22.5	3 650	114 000	92 800	229 000	6 180	4 080	24 000	4 080	24 000	1.9	10.9
				143 000	116 000	305 000	8 240	7 150	39 000	7 150	39 000	2.6	
60 (120)	16 \times 23 \times 20	30	3 600	159 000	129 000	330 000	10 200	7 060	41 000	7 060	41 000	3.4	14.6
				207 000	168 000	462 000	14 300	13 600	72 000	13 600	72 000	4.7	
75 (150)	18 \times 26 \times 22	35	3 600	259 000	210 000	504 000	19 200	12 700	78 500	12 700	78 500	7.2	20.5
				355 000	288 000	756 000	28 700	28 600	153 000	28 600	153 000	9.5	

2) Basic load ratings comply with ISO standards (ISO 14728-1,14728-2):

C₅₀: Basic dynamic load rating for 50 km rated fatigue life

C₁₀₀: Basic dynamic load rating for 100 km rated fatigue life

RB Model: Dimension Tables

Flanged type (for both tapped and bolt mounting holes) RB-EM (High load/standard), RB-GM (Super-high load/long)

Reference number for preloaded assembly

RB 35 1000 EM C 2 - P6 3**

Model name	RB 35 1000 EM C 2 -** P6 3	Preload code 3: Z3
Size	RB 35 1000 EM C 2 -** P6 3	Accuracy code (Without NSK K1): P3, P4, P5, P6 (With NSK K1): K3, K4, K5, K6
Rail length (mm)	RB 35 1000 EM C 2 -** P6 3	Design serial number Added to the reference number.
Roller slide shape code: EM, GM	RB 35 1000 EM C 2 -** P6 3	Number of roller slides per rail
Material/surface treatment code C: Special high carbon steel (NSK standard)	RB 35 1000 EM C 2 -** P6 3	

Model No.	Assembly			Roller slide														Width W_1	Height H_1
	Height H	E	W_2	Width W	Length L	Mounting hole						L_1	K	T	Grease fitting				
						B	J	J_2	Number of holes	$M \times \text{pitch} \times l_1(l_2)$	Q_2				Hole size	T_1	N		
RB30EM RB30GM	38	6.5	31	90	110.8 135.4	72	52	44	6 8	M10×1.5×12 (8.5)	8.6	74 98.6	31.5	11	$\phi 3$	5	2.6	28	28
RB35EM RB35GM	44	6.5	33	100	123.8 152	82	62	52	6 8	M10×1.5×13 (11.5)	8.6	83.2 111.4	37.5	12	M6×0.75	6.5	11	34	31
RB45EM RB45GM	52	8	37.5	120	154 190	100	80	60	6 8	M12×1.75×15 (12.5)	10.5	105.4 141.4	44	13	M6×0.75	6.5	14	45	38
RB55EM RB55GM	63	9	43.5	140	184 234	116	95	70	6 8	M14×2×18 (18)	12.5	128 178	54	15	R _C 1/8	8.5	14	53	43.5
RB65EM RB65GM	75	10	53.5	170	228.4 302.5	142	110	82	6 8	M16×2×24 (21)	14.6	155.4 229.5	65	15	R _C 1/8	10	14	63	52

Notes: 1) Select either the standard dimension for pitch F as shown without parentheses or the semi-standard dimension as shown inside parentheses.
If not specified, the standard dimension for F will be applied.

High-Rigidity Series: RA/RB Model Roller Guides

☆RB30 uses a drive-in grease fitting

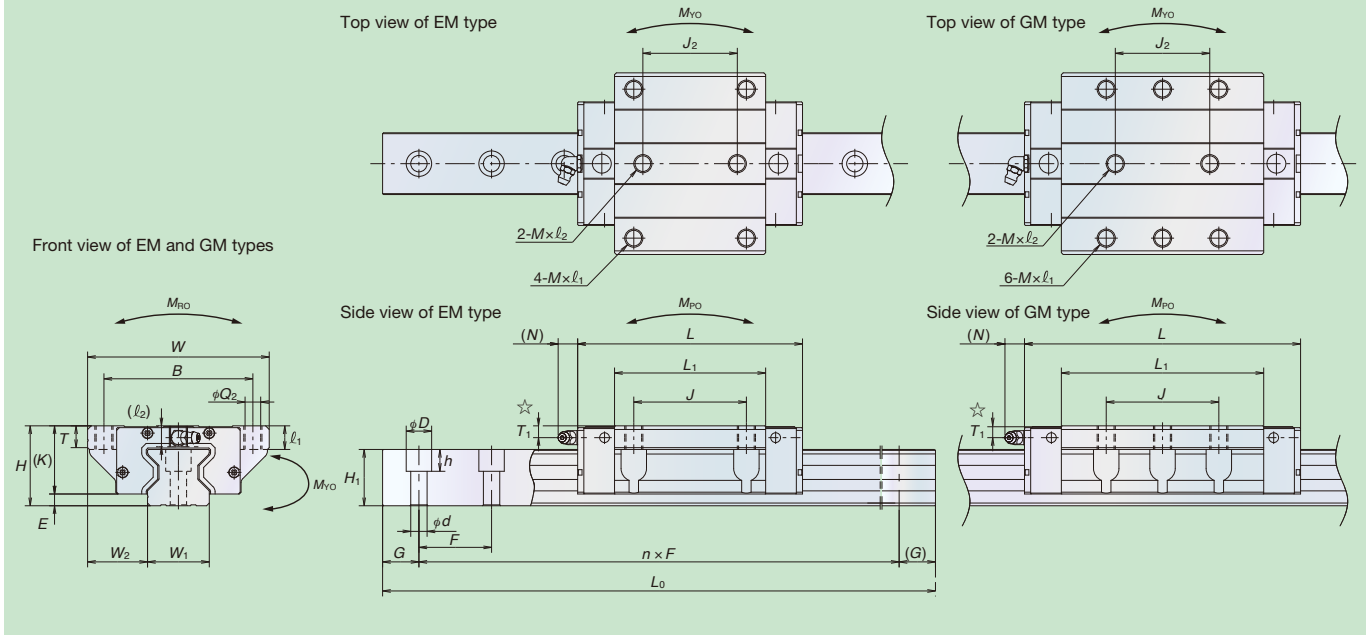

Unit: mm

Rail				Basic load ratings								Weight	
Pitch <i>F</i>	Mounting bolt hole <i>d</i> × <i>D</i> × <i>h</i>	<i>G</i> (reference)	Maximum length <i>L</i> _{0max}	2) Dynamic		Static <i>C</i> ₀ (N)	<i>M</i> _{R0}	Static moment (N·m)				Roller slide (kg)	Rail (kg/m)
				[50km] <i>C</i> ₅₀ (N)	[100km] <i>C</i> ₁₀₀ (N)			<i>M</i> _{P0}		<i>M</i> _{Y0}			
								One slide	Two slides	One slide	Two slides		
40 (80)	9×14×12	20	3 900	47 800	38 900	93 500	1 670	1 140	7 100	1 140	7 100	1.1	4.9
				58 500	47 600	121 000		2 170	1 950	11 500	1 950	11 500	
40 (80)	9×14×12	20	3 900	65 500	53 300	129 000	2 810	1 800	11 000	1 800	11 000	1.5	6.8
				82 900	67 400	175 000		3 810	3 250	17 800	3 250	17 800	
52.5 (105)	14×20×17	22.5	3 650	114 000	92 800	229 000	6 180	4 080	24 000	4 080	24 000	2.5	10.9
				143 000	116 000	305 000		8 240	7 150	39 000	7 150	39 000	
60 (120)	16×23×20	30	3 600	159 000	129 000	330 000	10 200	7 060	41 000	7 060	41 000	4.7	14.6
				207 000	168 000	462 000		14 300	13 600	72 000	13 600	72 000	
75 (150)	18×26×22	35	3 600	259 000	210 000	504 000	19 200	12 700	78 500	12 700	78 500	9.7	20.5
				355 000	288 000	756 000		28 700	28 600	153 000	28 600	153 000	

2) Basic load ratings comply with ISO standards (ISO 14728-1,14728-2):

*C*₅₀: Basic dynamic load rating for 50 km rated fatigue life

*C*₁₀₀: Basic dynamic load rating for 100 km rated fatigue life

Worldwide Sales Offices

P: Phone F: Fax ☆: Head Office

NSK LTD.-HEADQUARTERS, TOKYO, JAPAN

Nissei Bldg., 1-6-3 Ohsaki, Shinagawa-ku, Tokyo 141-8560, Japan
INDUSTRIAL MACHINERY BUSINESS DIVISION-HEADQUARTERS
P: +81-3-3779-7227 F: +81-3-3779-7432
AUTOMOTIVE BUSINESS DIVISION-HEADQUARTERS
P: +81-3-3779-7189 F: +81-3-3779-7917

●Africa

South Africa:

NSK SOUTH AFRICA (PTY) LTD.

SANDTON 25 Galaxy Avenue, Linbro Business Park, Sandton 2146, South Africa
P: +27-011-458-3600 F: +27-011-458-3608

●Asia and Oceania

Australia:

NSK AUSTRALIA PTY. LTD.

MELBOURNE ☆ 100 Logis Boulevard, Dandenong South, Victoria, 3175, Australia
P: +61-3-9765-4400 F: +61-3-9765-4466
SYDNEY Suite A315, 20 Lexington Drive, Bella Vista, New South Wales, 2153, Australia
P: +61-2-9839-2300 F: +61-2-8824-5794
BRISBANE 1/69 Selhurst Street, Coopers Plains, Queensland 4108, Australia
P: +61-7-3347-2600 F: +61-7-3345-5376
PERTH Unit 1, 71 Tacoma Circuit, Canning Vale, Western Australia 6155, Australia
P: +61-8-9256-5000 F: +61-8-9256-1044

New Zealand:

NSK NEW ZEALAND LTD.

AUCKLAND Unit F, 70 Business Parade South, Highbrook, Business Park Auckland 2013, New Zealand
P: +64-9-276-4992 F: +64-9-276-4082

China:

NSK (SHANGHAI) TRADING CO., LTD.

JIANGSU No.8 NSK Rd., Huaqiao Economic Development Zone, Kunshan, Jiangsu, China (215332)
P: +86-512-5796-3000 F: +86-512-5796-3300

NSK (CHINA) INVESTMENT CO., LTD.

JIANGSU ☆ No.8 NSK Rd., Huaqiao Economic Development Zone, Kunshan, Jiangsu, China (215332)
P: +86-512-5796-3000 F: +86-512-5796-3300

BEIJING Room 1906, Beijing Fortune Bldg., No.5 Dong San Huan Bei Lu, Chao Yang District, Beijing, China (100004)
P: +86-10-6590-8161 F: +86-10-6590-8166

TIAN JIN Unit 4604, 46/F., Metropolitan Tower, 183 Nanjing Road, Heping District, Tianjin, China (300051)
P: +86-22-8319-5030 F: +86-22-8319-5033

CHANGCHUN Room 902-03, Changchun Hongwell International Plaza, No.3299 Renmin Street, Changchun, Jilin, China (130061)
P: +86-431-8898-8682 F: +86-431-8898-8670

SHENYANG Room 1101, China Resources Building, No. 286 Qingnian Street, Heping District, Shenyang Liaoning, China (110004)
P: +86-24-2334-2868 F: +86-24-2334-2058

DALIAN Room 1805 Xi Wang Tower, No.136 Zhongshan Road, Zhongshan District, Dalian, Liaoning, China (116001)
P: +86-411-8800-8168 F: +86-411-8800-8160

NANJING Room A1 22F, Golden Eagle International Plaza, No.89 Hanzhong Road, Nanjing, Jiangsu, China (210029)
P: +86-25-8472-6671 F: +86-25-8472-6687

FUZHOU Room 1801-1811, B1#1A Class Office Building, Wanda Plaza, No.8 Aojiang Road, Fuzhou, China (350009)
P: +86-591-8380-1030 F: +86-591-8380-1225

WUHAN Room 1512, No.198Yuncail Road, Office Building, Oceanwide City Square, JiangHan, District, WuHan, China (400039)
P: +86-27-8556-9630 F: +86-27-8556-9615

QINGDAO Room 802, Farglory International Plaza, No.26 Xianggang Zhong Road, Shinan District, Qingdao, Shandong, China (266071)
P: +86-532-5568-3877 F: +86-532-5568-3876

GUANGZHOU Room 1011-16, Yuexiu Financial Tower, No.28 Zhujiang Road East, Zhujiang New Town, Guangzhou, Guangdong, China (510627)
P: +86-20-3817-7800 F: +86-20-3786-4501

CHANGSHA Room 3209, Huayuan International Center, No.36, Section 2, Xiangjiang Middle Road, Tianxin District, Changsha, Hunan, China (410002)
P: +86-731-8571-3100 F: +86-731-8571-3255

LUOYANG Room 955, HUA-YANG PLAZA HOTEL, NO.88 Kaixuan W.Rd., Jian Xi District, Luoyang,Henan Province, China (471003)
P: +86-379-6069-6188 F: +86-379-6069-6180

XI'AN Room 1007, B Changan Metropolis Center, No.88 Nanguanzheng Steet, Xi'an, Shanxi, China (710068)
P: +86-29-8765-1896 F: +86-29-8765-1895

CHONGQING Room 612, Commercial Apartment, Athestel Hotel, No.288, Keyuan Rd.4, Jiulongpo District, Chongqing, China (400039)
P: +86-23-6806-5310 F: +86-23-6806-5292

CHENGDU Room1117, Lippo Tower, No.62 North Kehua Road, Chengdu, Sichuan, China (610041)
P: +86-28-8528-3680 F: +86-28-8528-3690

NSK CHINA SALES CO., LTD.

JIANGSU No.8 NSK Rd., Huaqiao Economic Development Zone, Kunshan, Jiangsu, China (215332)
P: +86-512-5796-3000 F: +86-512-5796-3300

NSK HONG KONG LTD.

HONG KONG ☆ Suite 705, 7th Floor, South Tower, World Finance Centre, Harbour City, T.S.T, Kowloon, Hong Kong, China
P: +852-2739-9933 F: +852-2739-9323

SHENZHEN Room 624-626, 6/F, Kerry Center, Renminnan Road, Shenzhen, Guangdong, China
P: +86-755-25904886 F: +86-755-25904883

Taiwan:

TAIWAN NSK PRECISION CO., LTD.

TAIPEI ☆ 10F-A6, No.168, Sec.3, Nanjing East Rd., Zhongshan Dist., Taipei City 104, Taiwan
P: +886-2-2772-3355 F: +886-2-2772-3300

TAICHUNG 3F. -2, No. 540, Sec. 3, Taiwan Blvd., Xitun Dist., Taichung City 407, Taiwan
P: +886-4-2708-3393 F: +886-4-2708-3395

TAINAN Rm. A1, 9F., No.189, Sec. 1, Yongfu Rd., West Central Dist., Tainan City 700, Taiwan
P: +886-6-215-6058 F: +886-6-215-5518

India:

NSK BEARINGS INDIA PRIVATE LTD.

CHENNAI ☆ TVH Belicia Towers, 2nd Floor, Block I, No.71/1, MRC Nagar Main Road, MRC Nagar, Chennai-600 028,India
P: +91-44-2847-9600 F: +91-44-2847-9601

MUMBAI No.321, A Wing, Ahura Centre, 82, Mahakali Caves Road, Andheri (E), Mumbai-400 093, India
P: +91-22-2838-7787

JAMSHEDPUR 13/A, 2nd Floor, Circuit House Area, North West Layout, Road No.12, (Near Sai Baba Mandir), Sonari, Jamshedpur-831 011, Jharkhand, India
P: +91-657-2421144

GURGAON Unit No. 202, 2nd Floor, 'A' Block, Iris Tech Park, Sector - 48 (Sohna Road), Gurgaon-122018, Haryana, India
P: +91-124-4838000

Indonesia:

PT. NSK INDONESIA

JAKARTA Summitmas II, 6th Floor, Jl. Jend Sudirman Kav. 61-62, Jakarta 12190, Indonesia
P: +62-21-252-3458 F: +62-21-252-3223

Korea:

NSK KOREA CO., LTD.

SEOUL Posco Center (West Wing) 9F, 440, Teheran-ro, Gangnam-gu, Seoul, 06194, Korea
P: +82-2-3287-0300 F: +82-2-3287-0345

Malaysia:

NSK BEARINGS (MALAYSIA) SDN. BHD.

SHAH ALAM ☆ No. 2, Jalan Pemaju, U1/15, Seksyen U1, Hicom Glenmarie Industrial Park, 40150 Shah Alam, Selangor, Malaysia
P: +60-3-7803-8859 F: +60-3-7806-5982

PRAI No.24, Jalan kikir, Taman Inderawasih, 13600 Prai, Penang, Malaysia
P: +60-4-3902275 F: +60-4-3991830

JOHOR BAHRU 88 Jalan Ros Merah 2/17, Taman Johor Jaya, 81100 Johor Bahru, Johor, Malaysia
P: +60-7-3546290 F: +60-7-3546291

IPOH No.10&10A, Jalan Industri Paloh, Kawasan Perindustrian Ringan Paloh, 30200 Ipoh, Perak,Malaysia
P: +60-5-2555000 F: +60-5-2553373

Philippines:

NSK REPRESENTATIVE OFFICE

MANILA 8th Floor The Salcedo Towers 169 H.V. Dela Costa St.,Salcedo Villege Makati City, Philippines 1227
P: +63-2-893-9543 F: +63-2-893-9173

Singapore:

NSK INTERNATIONAL (SINGAPORE) PTE LTD.

SINGAPORE 238A, Thomson Road, #24-01/05, Novena Square Tower A, Singapore 307684
P: +65-6496-8000 F: +65-6250-5845

NSK SINGAPORE (PRIVATE) LTD.

SINGAPORE 238A, Thomson Road, #24-01/05, Novena Square Tower A, Singapore 307684
P: +65-6496-8000 F: +65-6250-5845

Thailand:

NSK BEARINGS (THAILAND) CO.,LTD.

BANGKOK 26 Soi Onnuch 55/1 Pravet Subdistrict, Pravet District, Bangkok 10250, Thailand
P: +66-2320-2555 F: +66-2320-2826

Vietnam:

NSK VIETNAM CO., LTD.

HANOI Techno Center, Room 204-205, Thang Long Industrial Park, Dong Anh District, Hanoi, Vietnam
P: +84-24-3955-0159 F: +84-24-3955-0158

NSK REPRESENTATIVE OFFICE

HO CHI MINH CITY Unit 609, The Landmark Building, 5B Ton Duc Thang Street, District 1, Ho Chi Minh City, Vietnam
P: +84-28-3822-7907 F: +84-28-3822-7910

Worldwide Sales Offices

P: Phone F: Fax ☆: Head Office

● Europe

United Kingdom:

NSK EUROPE LTD. (EUROPEAN HEADQUARTERS)

MAIDENHEAD Belmont Place, Belmont Road, Maidenhead, Berkshire SL6 6TB, U.K.
P: +44-1628-509-800 F: +44-1628-509-808

NSK UK LTD.

NEWARK Northern Road, Newark, Nottinghamshire NG24 2JF, U.K.
P: +44-1636-605-123 F: +44-1636-605-000

France:

NSK FRANCE S.A.S.

PARIS Quartier de l'Europe, 2 Rue Georges Guynemer, 78283 Guyancourt, France
P: +33-1-30-57-39-39 F: +33-1-30-57-00-01

Germany:

NSK DEUTSCHLAND GMBH

DUSSELDORF ☆ Harkortstrasse 15, D-40880 Ratingen, Germany
P: +49-2102-4810 F: +49-2102-4812-290

STUTTGART Liebknechtstrasse 33, D-70565 Stuttgart-Vaihingen, Germany
P: +49-711-79082-0 F: +49-711-79082-289

WOLFSBURG Tischlerstrasse 3, D-38440 Wolfsburg, Germany
P: +49-5361-27647-10 F: +49-5361-27647-70

Italy:

NSK ITALIA S.P.A.

MILANO Via Garibaldi 215, Garbagnate Milanese (Milano) 20024, Italy
P: +39-299-5191 F: +39-299-025778

Netherlands:

NSK EUROPEAN DISTRIBUTION CENTRE B.V.

TILBURG Brakman 54, 5047 SW Tilburg, Netherlands
P: +31-13-4647647 F: +31-13-4641082

Poland:

NSK REPRESENTATIVE OFFICE

WARSAW Ul. Migdalowa 4/73, 02-796, Warsaw, Poland
P: +48-22-645-1525 F: +48-22-645-1529

Russia:

NSK POLSKA SP. Z O.O.

SAINT-PETERSBURG Office 1 703, Bldg 29, 18th Line of Vasilievskiy Ostrov, Saint-Petersburg, Russia, 199178
P: +7-812-332-5071 F: +7-812-332-5072

Spain:

NSK SPAIN S.A.

BARCELONA C/Tarragona, 161 Cuerpo Bajo, 2a Planta, 08014, Barcelona, Spain
P: +34-93-289-2763 F: +34-93-433-5776

Turkey:

NSK RULMANLARI ORTA DOGU TIC. LTD. STI.

ISTANBUL Cevizli Mahallesi, D-100 Güney Yanyolu, Kuriş Kule İş Merkezi No:2 Kat:4, P.K.:
34846, Cevizli-Kartal-Istanbul, Turkey
P: +90-216-5000-675 F: +90-216-5000-676

United Arab Emirates:

NSK BEARINGS GULF TRADING CO.

DUBAI JAFZA View 19, Floor 24 Office LB192402/3, PO Box 262163, Downtown Jebel Ali,
Dubai, U.A.E
P: +971-(0)4-804-8200 F: +971-(0)4-884-7227

● North and South America

United States of America:

NSK AMERICAS, INC. (AMERICAN HEADQUARTERS)

ANN ARBOR 4200 Goss Road, Ann Arbor, Michigan 48105, U.S.A.
P: +1-734-913-7500 F: +1-734-913-7511

NSK CORPORATION

ANN ARBOR 4200 Goss Road, Ann Arbor, Michigan 48105, U.S.A.
P: +1-734-913-7500 F: +1-734-913-7511

NSK PRECISION AMERICA, INC.

FRANKLIN ☆ 3450 Bearing Drive, Franklin, Indiana 46131, U.S.A.
P: +1-317-738-5000 F: +1-317-738-5050

SAN JOSE 780 Montague Expressway, Suite 505, San Jose, California, 95131, U.S.A.
P: +1-408-944-9400 F: +1-408-944-9405

NSK LATIN AMERICA, INC.

MIAMI 11601 NW 107 Street, Suite 200, Miami Florida, 33178, U.S.A.
P: +1-305-477-0605 F: +1-305-477-0377

Canada:

NSK CANADA INC.

TORONTO ☆ 317 Rutherford Road South, Brampton, Ontario, L6W 3R5, Canada
P: +1-888-603-7667 F: +1-905-890-1938

MONTREAL 2150-32E Avenue Lachine, Quebec, Canada H8T 3H7
P: +1-514-633-1220 F: +1-800-800-2788

Argentina:

NSK ARGENTINA SRL

BUENOS AIRES Garcia del Rio 2477 Piso 7 Oficina "A" (1429) Buenos Aires-Argentina
P: +54-11-4704-5100 F: +54-11-4704-0033

Brazil:

NSK BRASIL LTDA.

SUZANO ☆ Av. Vereador João Batista Fitipaldi, 66, Vila Maluf, Suzano-SP-Brazil-CEP 08685-000
P: +55-11-4744-2500

JOINVILLE Rua Blumenau, 178, sala 910, Centro, Joinville-SC-Brazil-CEP 89204-250
P: +55-47-3422-2239

Peru:

NSK PERU S.A.C.

LIMA Calle Teniente Enrique Palacios 360 Oficina 311 Miraflores, Lima, Peru
P: +51-493-4385

Mexico:

NSK RODAMIENTOS MEXICANA, S.A. DE C.V.

SILAO, GUANAJUATO Circuito Mexiamora Oriente No. 331, Parque Industrial Santa Fe I, Puerto Interior. Silao, Guanajuato, Mexico. C.P. 36275
P: +52-472-500-9500 F: +52-472-103-9403

<As of August 2021>

For the latest information, please refer to the NSK website.

www.nsk.com

Every care has been taken to ensure the accuracy of data in this publication, but NSK Ltd. accepts no liability for any loss or damage incurred from errors or omissions. As we pursue continuous improvement, all content (text, images, product appearances, specifications, etc.) contained in this publication is subject to change without notice. Unauthorized copying and/or use of the contents of this publication is strictly prohibited. Please investigate and follow the latest product export laws, regulations, and permit procedures when exporting to other countries.

MOTION & CONTROL™
NSK

