

NSK

NSKHPS SPHERICAL ROLLER BEARINGS

THE STANDARD IN HIGH PERFORMANCE



STAY IN MOTION. STAY IN CONTROL.



FIELD-PROVEN TO OUTPERFORM AND OUTLAST: NSKHPS

Extreme heavy and impact loads in steelmaking, mining and construction. Extreme speeds and high heat in papermaking. Extreme reliability where and when unexpected machine and equipment downtime is intolerable.

For the spherical roller bearings employed in industry's most challenging applications, the expectations are invariably demanding: to run harder, to run faster, to run longer. And to transcend being mere load bearing components to being performance enhancers - mitigating maintenance and operating costs, improving throughput and profitability.

Decisively.

That measure of differentiation is achieved by better manufacturing processes, better material technology, better design fundamentals.

That differentiation is NSKHPS Spherical Roller Bearings.



**PERFORMANCE YOU CAN
COUNT ON.**

NSKHPS Spherical Roller Bearings are the synthesis of NSK technologies, with material engineering, tribology, mechanical design and advanced manufacturing engaged and applied. The outcome is a spherical roller bearing engineered to significantly outperform and outlast conventional iterations, meeting industry's ever-increasing challenges with significant and proven advantages:

- › Dramatically longer and reliable operating life
- › Higher dynamic load-carrying capacity
- › Higher limiting speeds
- › High temperature dimensional stability
- › Downsizing potential with no machine capacity loss

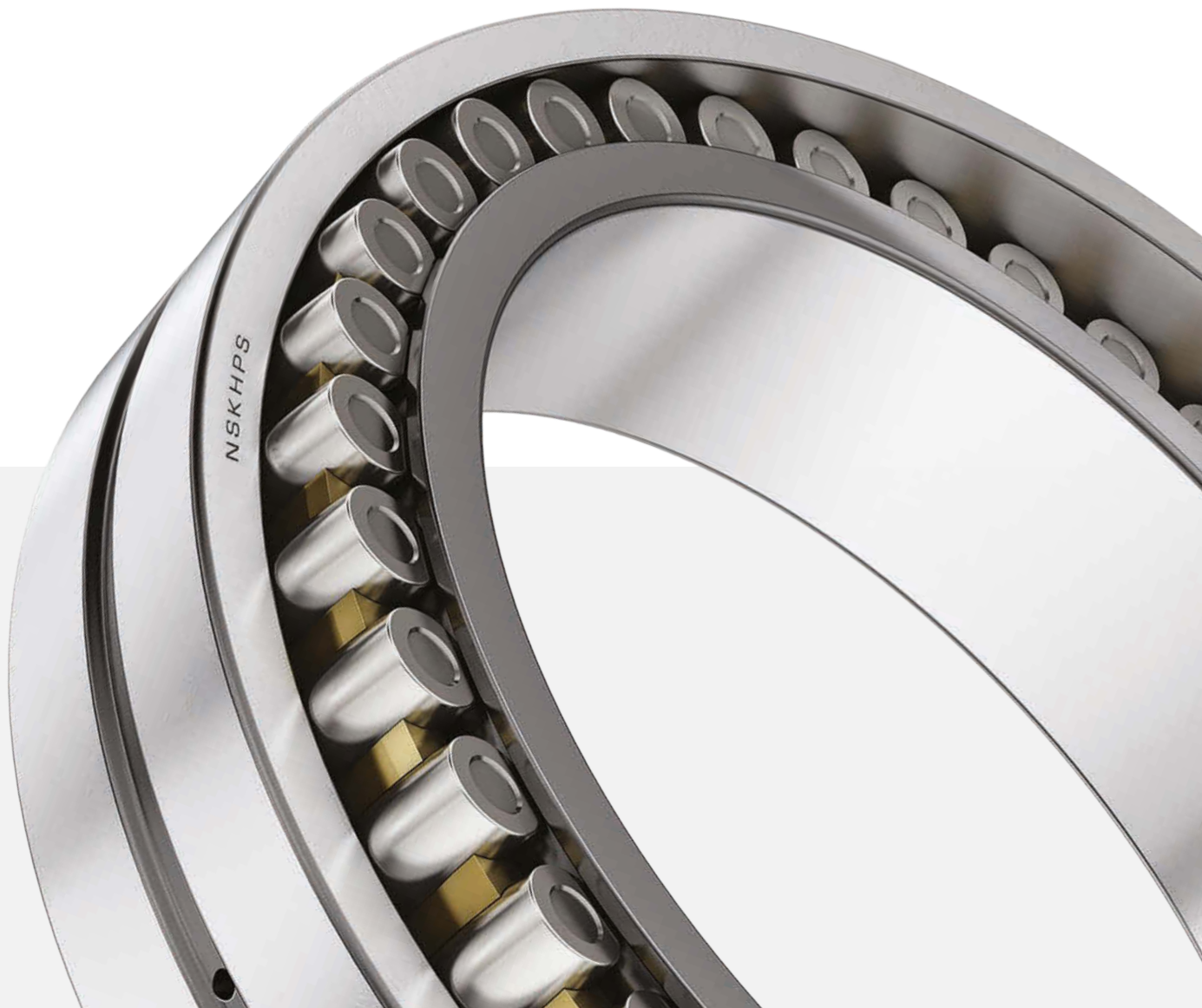

DESIGN FEATURES

NSKHPS Spherical Roller Bearings are optimized by design to deliver higher load carrying capacity, operate with higher limiting speeds, and perform reliably for a longer operating life. In conventional applications, their high performance capacity can also enable downsizing the design envelope for machinery and equipment.



DESIGN FEATURES

- › Manufactured with high purity steel for superior fatigue strength
- › Optimized, high capacity internal design
- › With wear-resistant surface hardened pressed steel and heavy-duty machined brass cages
- › Advanced raceway surface finishing for durability and wear resistance
- › High temperature dimensional stability: up to 200° C
- › Radial internal clearances C2, C-normal, C3, C4 and C5
- › Dimensional series 213, 222, 223, 230, 231, 232, 239, 240 and 241
- › For shaft diameters from 40 to 420 mm

PRESSED STEEL CAGE

- › High-strength cage with special nitriding surface treatment for superior wear resistance enabling higher operating speeds
- › Roller guidance is delivered by the central cage flanges, eliminating the need for a guide ring allowing for larger rollers, higher load capacity and longer life



MACHINED BRASS CAGE

- › Heavy duty cage design for superior performance in applications subject to heavy and/or impact loading
- › Cage pocket geometry and finger length provide superior roller guidance and controlled roller skew
- › Precision-machined contours optimize lubricant flow to rolling contact surfaces



ADVANCED RACEWAY SURFACE FINISH

With NSKHPS spherical roller bearings, superior ring grinding technology in conjunction with optimized roller-to-raceway profiles control roller motion within the bearing, reducing bearing wear and improving bearing fatigue life.

Additionally, NSK applies a super-finish process to raceway surfaces to remove remaining material asperity peaks - at a micro level - to improve lubrication performance and augment wear resistance.

BEARING DIMENSIONS AND OPERATING VALUES

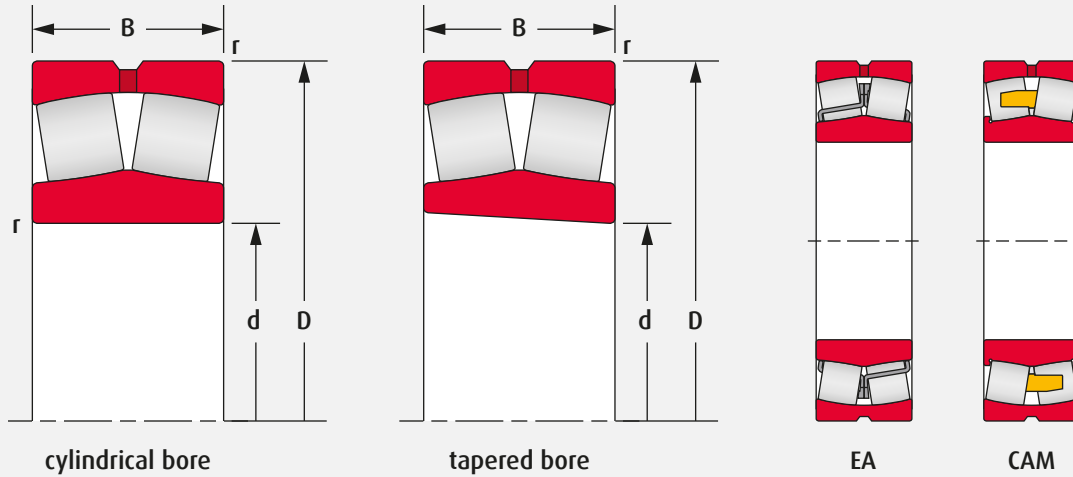

BASIC BEARING NO.		BEARING DIMENSIONS				BASIC LOAD RATINGS		LIMITING SPEED	
		mm				kN		rpm	
Cylindrical Bore	Tapered Bore	d	D	B	r (min)	Dynamic	Static	Grease	Oil
22208EAE4	22208EAKE4	40	80	23	1.1	113	99	5 600	7 100
21308EAE4	21308EAKE4		90	23	1.5	118	111	6 000	7 500
22308EAE4	22308EAKE4		90	33	1.5	170	153	5 300	6 700
22209EAE4	22209EAKE4	45	85	23	1.1	118	111	6 000	7 500
21309EAE4	21309EAKE4		100	25	1.5	149	144	5 000	6 300
22309EAE4	22309EAKE4		100	36	1.5	207	195	4 500	5 600
22210EAE4	22210EAKE4	50	90	23	1.1	124	119	5 600	7 100
21310EAE4	21310EAKE4		110	27	2.0	178	174	4 500	5 600
22310EAE4	22310EAKE4		110	40	2.0	246	234	4 300	5 300
22211EAE4	22211EAKE4	55	100	25	1.5	149	144	5 300	6 700
21311EAE4	21311EAKE4		120	29	2.0	178	174	4 500	5 600
22311EAE4	22311EAKE4		120	43	2.0	292	292	3 800	4 800
22212EAE4	22212EAKE4	60	110	28	1.5	178	174	4 800	6 000
21312EAE4	21312EAKE4		130	31	2.1	238	244	3 800	4 800
22312EAE4	22312EAKE4		130	46	2.1	340	340	3 600	4 500
22213EAE4	22213EAKE4	65	120	31	1.5	221	230	4 300	5 300
21313EAE4	21313EAKE4		140	33	2.1	264	275	3 600	4 500
22313EAE4	22313EAKE4		140	48	2.1	375	380	3 200	4 000
22214EAE4	22214EAKE4	70	125	31	1.5	225	232	4 000	5 300
21314EAE4	21314EAKE4		150	35	2.1	310	325	3 200	4 000
22314EAE4	22314EAKE4		150	51	2.1	425	435	3 000	3 800
22215EAE4	22215EAKE4	75	130	31	1.5	238	244	4 000	5 000
21315EAE4	21315EAKE4		160	37	2.1	310	325	3 200	4 000
22315EAE4	22315EAKE4		160	55	2.1	485	505	2 800	3 600

Dimensions of Oil Grooves and Holes (mm)

NOMINAL BEARING WIDTH		OIL GROOVE WIDTH	OIL HOLE DIAMETER
B			
Over	Incl.	W	d _{OH}
18	30	5	2.5
30	40	6	3
40	50	7	4
50	65	8	5
65	80	10	6

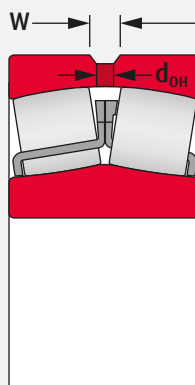

Number of Oil Holes

NOMINAL BEARING O.D.		NUMBER OF HOLES
D		
Over	Incl.	
—	180	4
180	250	6

BASIC BEARING NO.		BEARING DIMENSIONS				BASIC LOAD RATINGS		LIMITING SPEED	
		mm				kN		rpm	
Cylindrical Bore	Tapered Bore	d	D	B	r (min)	Dynamic	Static	Grease	Oil
22216EAE4	22216EAKE4	80	140	33	2.0	264	275	3 600	4 500
21316EAE4	21316EAKE4		170	39	2.1	355	375	3 000	3 800
22316EAE4	22316EAKE4		170	58	2.1	540	565	2 600	3 400
22217EAE4	22217EAKE4	85	150	36	2.0	310	325	3 400	4 300
21317EAE4	21317EAKE4		180	41	3.0	360	395	3 000	4 000
22317EAE4	22317EAKE4		180	60	3.0	600	630	2 400	3 200
22218EAE4	22218EAKE4	90	160	40	2.0	360	395	3 200	4 000
21318EAE4	21318EAKE4		190	43	3.0	415	450	2 800	3 600
22318EAE4	22318EAKE4		190	64	3.0	665	705	2 400	3 000
22219EAE4	22219EAKE4	95	170	43	2.1	415	450	3 000	3 800
21319CAME4	21319CAMKE4		200	45	3.0	430	435	1 500	2 000
22319EAE4	22319EAKE4		200	67	3.0	735	780	2 200	2 800
22220EAE4	22220EAKE4	100	180	46	2.1	455	490	2 800	3 600
23220CAME4	23220CAMKE4		180	60.3	2.1	525	605	1 600	2 200
21320CAME4	21320CAMKE4		215	47	3.0	495	485	1 400	1 900
22320EAE4	22320EAKE4		215	73	3.0	860	930	2 000	2 600
23122CAME4	23122CAMKE4	110	180	56	2.0	480	630	1 600	2 000
24122CAME4	24122CAMK30E4		180	69	2.0	575	750	1 600	2 000
22222EAE4	22222EAKE4		200	53	2.1	605	645	2 800	3 600
23222CAME4	23222CAMKE4		200	69.8	2.1	645	760	1 500	1 900
21322CAME4	21322CAMKE4		240	50	3.0	565	545	1 300	1 700
22322EAE4	22322EAKE4		240	80	3.0	1 030	1 120	1 900	2 400

BEARING DIMENSIONS AND OPERATING VALUES

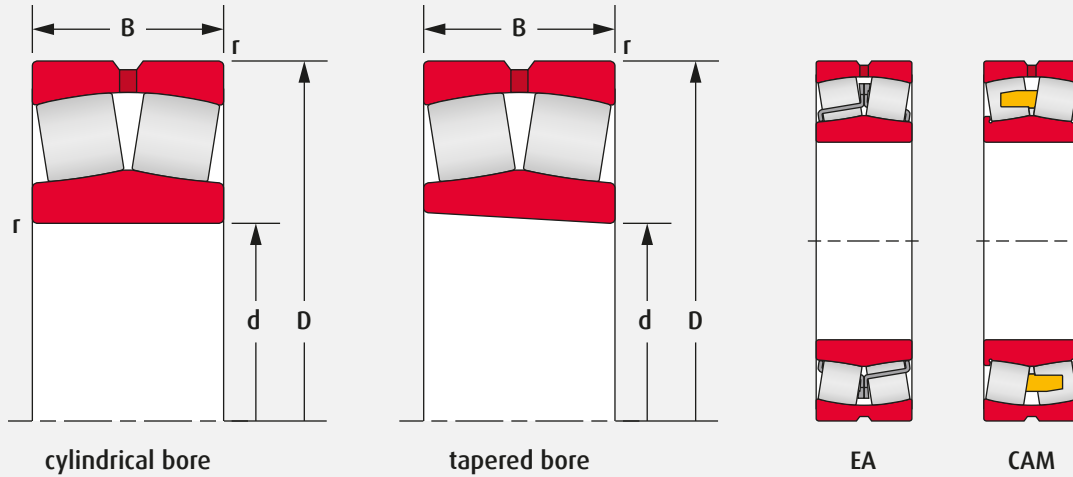

BASIC BEARING NO.		BEARING DIMENSIONS				BASIC LOAD RATINGS		LIMITING SPEED	
		mm				kN		rpm	
Cylindrical Bore	Tapered Bore	d	D	B	r (min)	Dynamic	Static	Grease	Oil
23024CAME4	23024CAMKE4	120	180	46	2.0	395	525	1 800	2 200
24024CAME4	24024CAMK30E4		180	60	2.0	480	680	1 500	2 000
23124CAME4	23124CAMKE4		200	62	2.0	580	720	1 400	1 800
24124CAME4	24124CAMK30E4		200	80	2.0	695	905	1 400	1 800
22224EAE4	22224EAKE4		215	58	2.1	685	765	2 400	3 000
23224CAME4	23224CAMKE4		215	76	2.1	790	970	1 300	1 700
22324EAE4	22324EAKE4		260	86	3.0	1 190	1 320	1 700	2 200
23026CAME4	23026CAMKE4		130	200	52	2.0	500	655	1 700
24026CAME4	24026CAMK30E4	200		69	2.0	620	865	1 400	1 800
23126CAME4	23126CAMKE4	210		64	2.0	630	825	1 300	1 700
24126CAME4	24126CAMK30E4	210		80	2.0	735	1 010	1 300	1 700
22226EAE4	22226EAKE4	230		64	3.0	820	940	2 200	2 600
23226CAME4	23226CAMKE4	230		80	3.0	875	1 080	1 200	1 600
22326CAME4	22326CAMKE4	280		93	4.0	1 240	1 350	1 300	1 600
23028CAME4	23028CAMKE4	140		210	53	2.0	525	715	1 600
24028CAME4	24028CAMK30E4		210	69	2.0	635	905	1 300	1 700
23128CAME4	23128CAMKE4		225	68	2.1	725	945	1 200	1 600
24128CAME4	24128CAMK30E4		225	85	2.1	835	1 160	1 200	1 600
22228CAME4	22228CAMKE4		250	68	3.0	835	945	1 400	1 700
23228CAME4	23228CAMKE4		250	88	3.0	1 040	1 300	1 100	1 500
22328CAME4	22328CAMKE4		300	102	4.0	1 450	1 590	1 200	1 500

Dimensions of Oil Grooves and Holes (mm)

NOMINAL BEARING WIDTH		OIL GROOVE WIDTH	OIL HOLE DIAMETER
B			
Over	Incl.	W	d _{OH}
40	50	7	4
50	65	8	5
65	80	10	6
80	100	12	8
100	120	15	10

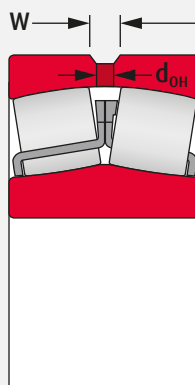

Number of Oil Holes

NOMINAL BEARING O.D.		NUMBER OF HOLES
D		
Over	Incl.	
—	180	4
180	250	6
250	315	6
315	400	6

BASIC BEARING NO.		BEARING DIMENSIONS				BASIC LOAD RATINGS		LIMITING SPEED	
		mm				kN		rpm	
Cylindrical Bore	Tapered Bore	d	D	B	r (min)	Dynamic	Static	Grease	Oil
23030CAME4	23030CAMKE4	150	225	56	2.1	590	815	1 400	1 800
24030CAME4	24030CAMK30E4		225	75	2.1	740	1 090	1 200	1 500
23130CAME4	23130CAMKE4		250	80	2.1	905	1 180	1 100	1 400
24130CAME4	24130CAMK30E4		250	100	2.1	1 070	1 450	1 100	1 400
22230CAME4	22230CAMKE4		270	73	3.0	955	1 120	1 300	1 600
23230CAME4	23230CAMKE4		270	96	3.0	1 220	1 560	1 100	1 400
22330CAME4	22330CAMKE4		320	108	4.0	1 530	1 690	1 100	1 400
23932CAME4	23932CAMKE4		220	45	2.0	450	675	1 400	1 800
23032CAME4	23032CAMKE4	160	240	60	2.1	675	955	1 300	1 700
24032CAME4	24032CAMK30E4		240	80	2.1	845	1 260	1 100	1 400
23132CAME4	23132CAMKE4		270	86	2.1	1 070	1 400	1 000	1 300
24132CAME4	24132CAMK30E4		270	109	2.1	1 240	1 670	1 000	1 300
22232CAME4	22232CAMKE4		290	80	3.0	1 140	1 320	1 200	1 500
23232CAME4	23232CAMKE4		290	104	3.0	1 370	1 770	1 000	1 300
22332CAME4	22332CAMKE4		340	114	4.0	1 700	1 900	1 100	1 300
23934CAME4	23934CAMKE4		230	45	2.0	450	680	1 300	1 700
23034CAME4	23034CAMKE4	170	260	67	2.1	795	1 090	1 200	1 600
24034CAME4	24034CAMK30E4		260	90	2.1	1 030	1 520	1 000	1 300
23134CAME4	23134CAMKE4		280	88	2.1	1 180	1 570	1 000	1 300
24134CAME4	24134CAMK30E4		280	109	2.1	1 280	1 770	1 000	1 300
22234CAME4	22234CAMKE4		310	86	4.0	1 240	1 500	1 100	1 400
23234CAME4	23234CAMKE4		310	110	4.0	1 500	1 910	900	1 200
22334CAME4	22334CAMKE4		360	120	4.0	1 970	2 110	1 000	1 200

BEARING DIMENSIONS AND OPERATING VALUES

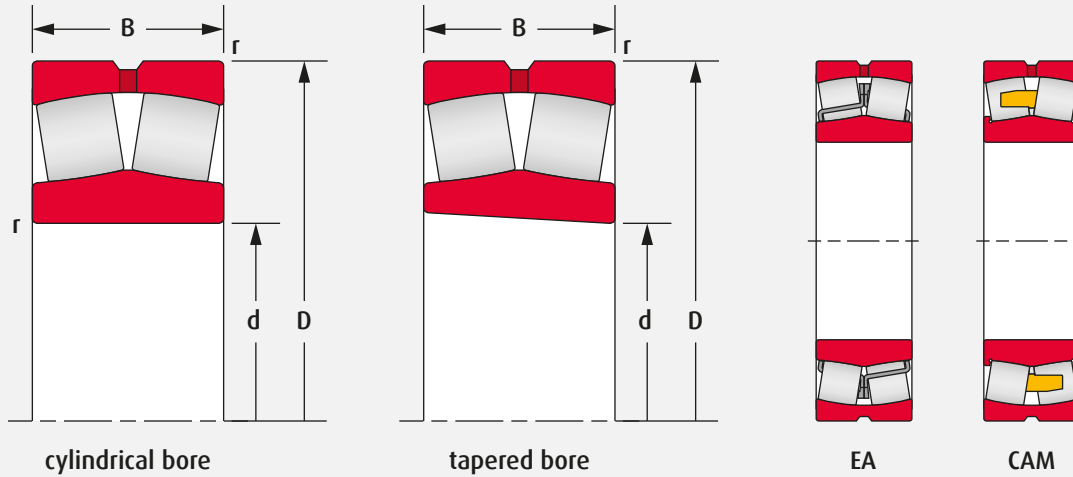

BASIC BEARING NO.		BEARING DIMENSIONS				BASIC LOAD RATINGS		LIMITING SPEED	
		mm				kN		rpm	
Cylindrical Bore	Tapered Bore	d	D	B	r (min)	Dynamic	Static	Grease	Oil
23936CAME4	23936CAMKE4	180	250	52	2.0	590	890	1 200	1 600
23036CAME4	23036CAMKE4		280	74	2.1	935	1 270	1 200	1 400
24036CAME4	24036CAMK30E4		280	100	2.1	1 210	1 750	950	1 200
23136CAME4	23136CAMKE4		300	96	3.0	1 320	1 760	900	1 200
24136CAME4	24136CAMK30E4		300	118	3.0	1 490	2 040	900	1 200
22236CAME4	22236CAMKE4		320	86	4.0	1 280	1 540	1 100	1 300
23236CAME4	23236CAMKE4		320	112	4.0	1 620	2 110	850	1 100
22336CAME4	22336CAMKE4		380	126	4.0	2 170	2 340	950	1 200
23938CAME4	23938CAMKE4	190	260	52	2.0	575	875	1 200	1 500
23038CAME4	23038CAMKE4		290	75	2.1	970	1 350	1 100	1 400
24038CAME4	24038CAMK30E4		290	100	2.1	1 220	1 840	900	1 200
23138CAME4	23138CAMKE4		320	104	3.0	1 480	2 020	850	1 100
24138CAME4	24138CAMK30E4		320	128	3.0	1 710	2 330	850	1 100
22238CAME4	22238CAMKE4		340	92	4.0	1 420	1 730	1 000	1 200
23238CAME4	23238CAMKE4		340	120	4.0	1 800	2 350	800	1 100
22338CAME4	22338CAMKE4		400	132	5.0	2 370	2 590	900	1 100
23940CAME4	23940CAMKE4	200	280	60	2.1	710	1 060	1 100	1 400
23040CAME4	23040CAMKE4		310	82	2.1	1 180	1 700	1 000	1 300
24040CAME4	24040CAMK30E4		310	109	2.1	1 420	2 120	850	1 100
23140CAME4	23140CAMKE4		340	112	3.0	1 700	2 330	800	1 000
24140CAME4	24140CAMK30E4		340	140	3.0	1 960	2 660	800	1 000
22240CAME4	22240CAMKE4		360	98	4.0	1 620	2 010	950	1 200
23240CAME4	23240CAMKE4		360	128	4.0	2 070	2 750	750	1 000
22340CAME4	22340CAMKE4		420	138	5.0	2 500	2 990	850	1 000

Dimensions of Oil Grooves and Holes (mm)

NOMINAL BEARING WIDTH		OIL GROOVE WIDTH	OIL HOLE DIAMETER
B			
Over	Incl.	W	d _{OH}
50	65	8	5
65	80	10	6
80	100	12	8
100	120	15	10
120	160	20	12
160	200	25	15

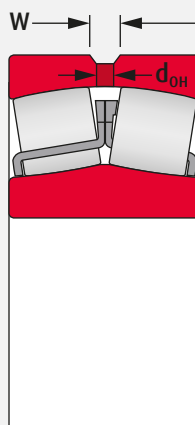

Number of Oil Holes

NOMINAL BEARING O.D.		NUMBER OF HOLES
D		
Over	Incl.	
180	250	6
250	315	6
315	400	6
400	500	6
500	630	8

BASIC BEARING NO.		BEARING DIMENSIONS				BASIC LOAD RATINGS		LIMITING SPEED	
		mm				kN		rpm	
Cylindrical Bore	Tapered Bore	d	D	B	r (min)	Dynamic	Static	Grease	Oil
23944CAME4	23944CAMKE4	220	300	60	2.1	785	1 240	1 000	1 300
23044CAME4	23044CAMKE4		340	90	3.0	1 360	1 980	950	1 200
24044CAME4	24044CAMK30E4		340	118	3.0	1 640	2 490	750	1 000
23144CAME4	23144CAMKE4		370	120	4.0	1 960	2 710	710	950
24144CAME4	24144CAMK30E4		370	150	4.0	2 250	3 200	710	950
22244CAME4	22244CAMKE4		400	108	4.0	1 960	2 430	850	1 000
23244CAME4	23244CAMKE4		400	144	4.0	2 520	3 400	670	900
22344CAME4	22344CAMKE4		460	145	5.0	2 940	3 400	750	950
23948CAME4	23948CAMKE4		240	320	60	2.1	795	1 300	950
23048CAME4	23048CAMKE4	360		92	3.0	1 450	2 140	850	1 100
24048CAME4	24048CAMK30E4	360		118	3.0	1 730	2 730	710	950
23148CAME4	23148CAMKE4	400		128	4.0	2 230	3 100	670	850
24148CAME4	24148CAMK30E4	400		160	4.0	2 660	3 800	670	850
22248CAME4	22248CAMKE4	440		120	4.0	2 340	2 890	750	950
23248CAME4	23248CAMKE4	440		160	4.0	3 050	4 050	630	800
22348CAME4	22348CAMKE4	500		155	5.0	3 250	3 800	670	850
23952CAME4	23952CAMKE4	260		360	75	2.1	1 170	1 870	850
23052CAME4	23052CAMKE4		400	104	4.0	1 780	2 580	800	950
24052CAME4	24052CAMK30E4		400	140	4.0	2 270	3 500	630	850
23152CAME4	23152CAMKE4		440	144	4.0	2 700	3 750	600	800
24152CAME4	24152CAMK30E4		440	180	4.0	3 200	4 700	600	800
22252CAME4	22252CAMKE4		480	130	5.0	2 720	3 400	670	850
23252CAME4	23252CAMKE4		480	174	5.0	3 400	4 550	560	750
22352CAME4	22352CAMKE4		540	165	6.0	3 900	4 600	630	800

BEARING DIMENSIONS AND OPERATING VALUES

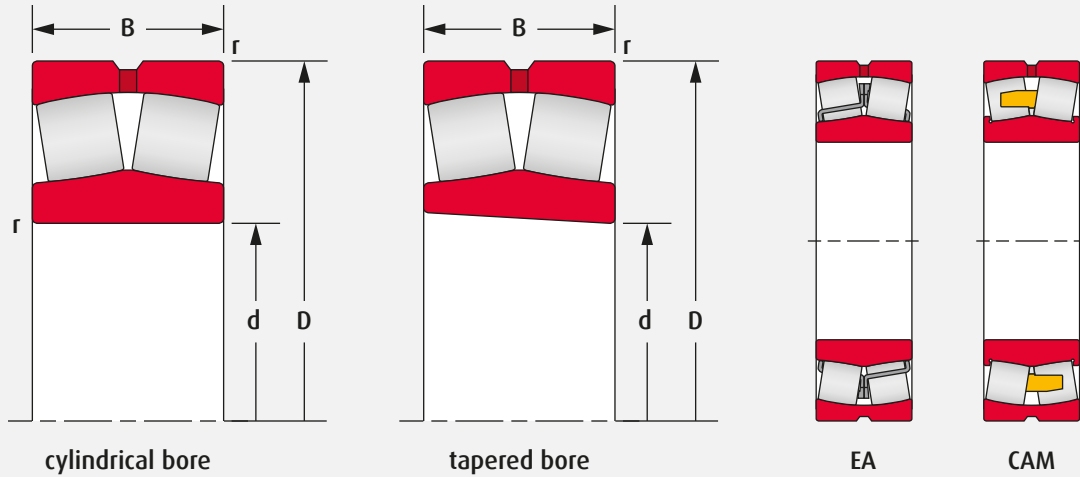

BASIC BEARING NO.		BEARING DIMENSIONS				BASIC LOAD RATINGS		LIMITING SPEED	
		mm				kN		rpm	
Cylindrical Bore	Tapered Bore	d	D	B	r (min)	Dynamic	Static	Grease	Oil
23956CAME4	23956CAMKE4	280	380	75	2.1	1 160	1 950	800	950
23056CAME4	23056CAMKE4		420	106	4.0	1 930	2 950	710	900
24056CAME4	24056CAMK30E4		420	140	4.0	2 350	3 800	600	800
23156CAME4	23156CAMKE4		460	146	5.0	2 790	4 000	560	750
24156CAME4	24156CAMK30E4		460	180	5.0	3 300	5 000	560	750
22256CAME4	22256CAMKE4		500	130	5.0	2 850	3 650	630	800
23256CAME4	23256CAMKE4		500	176	5.0	3 600	4 900	530	670
22356CAME4	22356CAMKE4		580	175	6.0	4 350	5 150	560	710
23960CAME4	23960CAMKE4	300	420	90	3.0	1 540	2 490	710	900
23060CAME4	23060CAMKE4		460	118	4.0	2 400	3 700	670	850
24060CAME4	24060CAMK30E4		460	160	4.0	2 890	4 600	530	710
23160CAME4	23160CAMKE4		500	160	5.0	3 350	4 800	500	670
24160CAME4	24160CAMK30E4		500	200	5.0	3 900	5 800	500	670
22260CAME4	22260CAMKE4		540	140	5.0	3 250	4 250	600	750
23260CAME4	23260CAMKE4		540	192	5.0	4 250	5 900	480	630
23964CAME4	23964CAMKE4		440	90	3.0	1 620	2 750	670	850
23064CAME4	23064CAMKE4	320	480	121	4.0	2 450	3 850	630	800
24064CAME4	24064CAMK30E4		480	160	4.0	3 050	5 050	500	670
23164CAME4	23164CAMKE4		540	176	5.0	3 850	5 500	480	600
24164CAME4	24164CAMK30E4		540	218	5.0	4 400	6 650	480	600
22264CAME4	22264CAMKE4		580	150	5.0	3 750	4 850	530	670
23264CAME4	23264CAMKE4		580	208	5.0	4 850	6 900	450	600

Dimensions of Oil Grooves and Holes (mm)

NOMINAL BEARING WIDTH		OIL GROOVE WIDTH	OIL HOLE DIAMETER
B			
Over	Incl.	W	d _{OH}
65	80	10	6
80	100	12	8
100	120	15	10
120	160	20	12
160	200	25	15
200	250	30	20

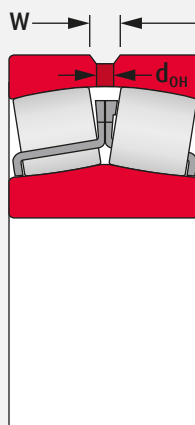

Number of Oil Holes

NOMINAL BEARING O.D.		NUMBER OF HOLES
D		
Over	Incl.	
315	400	6
400	500	6
500	630	8

BASIC BEARING NO.		BEARING DIMENSIONS				BASIC LOAD RATINGS		LIMITING SPEED	
		mm				kN		rpm	
Cylindrical Bore	Tapered Bore	d	D	B	r (min)	Dynamic	Static	Grease	Oil
23968CAME4	23968CAMKE4	340	460	90	3.0	1 670	2 840	630	800
23068CAME4	23068CAMKE4		520	133	5.0	2 850	4 400	560	710
24068CAME4	24068CAMK30E4		520	180	5.0	3 650	6 050	480	600
23168CAME4	23168CAMKE4		580	190	5.0	4 500	6 600	430	560
24168CAME4	24168CAMK30E4		580	243	5.0	5 300	7 900	430	560
23972CAME4	23972CAMKE4	360	480	90	3.0	1 730	3 050	600	750
23072CAME4	23072CAMKE4		540	134	5.0	2 990	4 700	530	670
24072CAME4	24072CAMK30E4		540	180	5.0	3 650	6 100	450	600
23172CAME4	23172CAMKE4		600	192	5.0	4 800	7 100	400	530
24172CAME4	24172CAMK30E4		600	243	5.0	5 250	8 000	400	530
23976CAME4	23976CAMKE4	380	520	106	4.0	2 340	4 100	530	670
23076CAME4	23076CAMKE4		560	135	5.0	3 150	5 100	530	630
24076CAME4	24076CAMK30E4		560	180	5.0	3 850	6 600	430	560
23980CAME4	23980CAMKE4	400	540	106	4.0	2 370	4 250	530	630
23080CAME4	23080CAMKE4		600	148	5.0	3 700	5 900	480	600
24080CAME4	24080CAMK30E4		600	200	5.0	4 500	7 600	400	500
23984CAME4	23984CAMKE4	420	560	106	4.0	2 340	4 250	500	600

DESIGNATION SYSTEM

NSKHPS SPHERICAL ROLLER BEARINGS







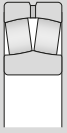

Dimension Series		Internal Design		Bore Type		Radial Internal Clearance		NSKHPS Symbol	
232	36	CA	M	K	E4	C3	S11	*H*	W507
Bore Reference Number		Cage Type		Lubrication Features		Stability Specification		Additional Features	

DESIGNATION		ATTRIBUTE	DESIGNATION		ATTRIBUTE
Dimensional Series	213	extra heavy duty type	Radial Internal Clearance	C2	less than normal clearance
	222	medium duty type		blank	normal clearance (CN)
	223	heavy duty type		C3	greater than normal clearance
	230	very light duty type		C4	greater than C3
	231	light duty type		C5	greater than C4
	232	medium duty type, wide	Stability Specification	S11	dimensionally stabilized up to 200°C, normally omitted from aftermarket part number
	239	extra-light duty type		NSKHPS Symbol	*H*
	240	very light duty type, wide	Additional Features		W31
	241	light duty type, wide		W507	W31 + E4 + S11 (with E4 and S11 omitted from the part number)
		W509		W31 + E7 + S11 (with E7 and S11 omitted from the part number)	
Bore Reference Number		multiply x 5 for bore diameter in mm; 500 mm and greater expressed with a "/" eg. /500 = 500 mm			
Internal Design	EA	high capacity design, steel cage			
	CA	high capacity design, brass cage			
Cage Type	blank	pressed steel cage			
	M	machined brass cage			
Bore Type	blank	cylindrical bore			
	K	1:12 tapered bore			
	K30	1:30 tapered bore			
Lubrication Features	E4	lubrication groove and holes in the outer ring			
	E7	lubrication groove and holes in the inner and outer ring			

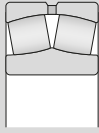
RANGE OF AVAILABILITY

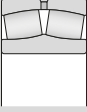
DIMENSION SERIES AND BORE SIZE



RANGE OF AVAILABILITY BY SERIES AND BORE DIAMETER										
DIMENSION SERIES										
	213	222	223	230	231	232	239	240	241	
BORE DIAMETER (MM)	40	Available	Available	Available						
	45	Available	Available	Available						
	50	Available	Available	Available						
	55	Available	Available	Available						
	60	Available	Available	Available						
	65	Available	Available	Available						
	70	Available	Available	Available						
	75	Available	Available	Available						
	80	Available	Available	Available						
	85	Available	Available	Available						
	90	Available	Available	Available						
	95	Available	Available	Available						
	100	Available	Available	Available			Available			
	110	Available	Available	Available		Available	Available			Available
	120	Available	Available	Available	Available	Available	Available		Available	Available
	130	Available	Available	Available	Available	Available	Available		Available	Available
	140	Available	Available	Available	Available	Available	Available		Available	Available
	150	Available	Available	Available	Available	Available	Available		Available	Available
	160	Available	Available	Available	Available	Available	Available	Available	Available	Available
	170	Available	Available	Available	Available	Available	Available	Available	Available	Available
	180	Available	Available	Available	Available	Available	Available	Available	Available	Available
	190	Available	Available	Available	Available	Available	Available	Available	Available	Available
	200	Available	Available	Available	Available	Available	Available	Available	Available	Available
	220	Available	Available	Available	Available	Available	Available	Available	Available	Available
	240	Available	Available	Available	Available	Available	Available	Available	Available	Available
	260	Available	Available	Available	Available	Available	Available	Available	Available	Available
	280	Available	Available	Available	Available	Available	Available	Available	Available	Available
	300	Available	Available	Available	Available	Available	Available	Available	Available	Available
320	Available	Available	Available	Available	Available	Available	Available	Available	Available	
340	Available	Available	Available	Available	Available	Available	Available	Available	Available	
360	Available	Available	Available	Available	Available	Available	Available	Available	Available	
380	Available	Available	Available	Available	Available	Available	Available	Available	Available	
400	Available	Available	Available	Available	Available	Available	Available	Available	Available	
420	Available	Available	Available	Available	Available	Available	Available	Available	Available	

 available with pressed steel and machined brass cage

 available with machined brass cage



NSK AMERICAS

United States
NSK Corporation
Ann Arbor MI
1.888.446.5675

Canada
NSK Canada Inc.
Mississauga ON
1.888.603.7667

Mexico
NSK Rodamientos Mexicana,
S.A. de C.V.
Silao Guanajuato MX
52.472.500.9500

Brazil
NSK Brasil Ltda.
Suzano SP
55.11.4744.2500

Argentina
NSK Argentina SRL
Buenos Aires
54.11.4704.5100

Latin America
NSK Latin America Inc.
Miramar FL
1.305.477.0605

Website: www.nskamericas.com
NSK Global: www.nsk.com

Every care has been taken to ensure the accuracy of the data contained in this brochure, but no liability can be accepted for any loss or damage suffered through errors or omissions.

Printed in the USA ©NSK 2023.
The contents of the publication are the copyright of the publishers.